

ARGUS[®]

INEX Inverter System User Manual

014-114-B2



Visit us at www.argus.ca

Power

This page intentionally left blank.

INEX Inverter System User Manual

014-114-B2

Applies to inverter modules 014-114-10, 014-115-10, 014-116-10, and 014-117-10.

The following documents and drawings are included in this manual to provide the necessary information required for installation, operation and fault diagnosis of the unit:

- **Specifications:** 014-114-B1
- **Installation and Operation Instructions:** 014-114-C0
- **Factory Service Information:** 048-527-10

Specifications for INEX Inverter System

Inverter Module Input

Nominal Voltage:	48Vdc
Operating Range:	40.5 to 58Vdc within rated limits
Under Voltage Warning Threshold:	45Vdc
Under Voltage Threshold:	40Vdc
Over Voltage Warning Threshold:	58Vdc
Over Voltage Threshold:	60Vdc
Isolation AC-DC:	Reinforced isolation (Pri-Sec) 4242Vdc/1min
Inrush current:	<2*I _{rated}
Isolation DC-enclosure:	707Vdc (varistors and filter capacitor removed)/1min
Input Protection:	Reverse polarity protection
Psophometric Noise Voltage:	≤1.0mV ITU-T O.41 (16.66 to 6000Hz)
Reflected Psophometric Noise Current:	<1% according to YD/T 777-2006
Reflected Relative Band Width Current Noise:	<10% (0-2MHz) according to YD/T 777-2006
Wide Band Noise:	<1.0mV (psophometric, 25Hz to 5kHz) <20mV _{rms} (25Hz to 20kHz)
Peak to Peak Noise:	<150mV up to 100MHz

Inverter Module Output

Power Capacity:	1000VA/800W, 1500VA/1200W
Waveform:	Pure sine wave
Power Factor:	0.8
Nominal Output Voltage:	110/115/120Vac or 208/220/230/240Vac
Voltage Regulation:	Max ±2%
Output Frequency:	50/60Hz
Frequency Variation:	Max ±0.5%
Frequency Setting:	Manually, field-selectable
Crest Factor:	3:1
T.H.D. (Current):	<3% for linear load, <5% for non-linear load
Capacitive/Inductive Load:	-0.8 to +0.8 without exceeding permissible distortion for resistive load
Efficiency:	Min 88% at rated load for 48Vdc system

Specifications for INEX Inverter System Continued

Current Limitation:	Electronic current limitation at overloads and short circuits
Isolation AC-enclosure:	Basic isolation (Pri-Gnd) 2121Vdc/1min
Surge Protection:	EN61000-4-5, Telcordia GR-1089 CORE, ANSI/IEEE C62.41, STD 587-1980
Dynamic Response:	Better than $\pm 10\%$ according to IEC 62040-3 Class 1
Over Load Protection:	1.5*Inom >20s 1.25*Inom temperature controlled Inom = 1000VA/output voltage Short circuit current = 16A for INV-4810EA and 30A for INV-4810A
Load Sharing:	<5%

Inverter Protection

Over Load:	When load exceeds 150% of power capacity, inverter will shut down after 20 seconds, and diagnose as overload fault with red LED lit. When load is 105~150%, inverter continuously delivers output power with a yellow LED lit for warning.
Output Voltage Fault Detection:	When the output RMS (root mean square) voltage is out of operating voltage range, the inverter unit will diagnose as output voltage high or low fault.
Inverter Output Short Circuit:	When output RMS voltage is below 40VAC and output RMS current is over 2A, the system will diagnose as inverter output short circuit fault with red LED on.
Input Voltage Detection:	When the DC input voltage is out of operating voltage range, the inverter system will shut down and release visual and audio alarms.
Over Temperature:	When inverter internal temperature rises over 100°C (212°F), the system will diagnose as over temperature fault with red LED flicker.

Maximum Number of INEX Inverter Modules for Parallel Connection



Model	With STS-050A	Without STS-050A
INV-4810A (1000VA/120Vac)	6	12
INV-4810EA (1000VA/240Vac)	12	12
INV-4815A (1500VA/120Vac)	4	8
INV-4815EA (1500VA/240Vac)	8	12

Note: Static transfer switch (STS)

INEX Controller Module

DC Nominal Voltage:	48Vdc
DC Voltage Range:	30 to 70Vdc
Over Current Protection:	2A fuse
LCD Display:	3" backlit LCD screen with 4 lines by 16 characters
LED Indicators:	Green/normal, yellow/warning, and red/fault

Specifications for INEX Inverter System Continued

Function Keys:	Esc Esc for cancellation PgUp  for cursor up movement PgDn  for cursor down movement Enter  for selection of comment validation
Buzzer:	Audio alarm when inverter, STS, or controller module operates abnormally. Esc key cancels audible alarm.
System Parameters:	BaudRate – setting controller com port baud rate Keypad tones – setting keypad tones Time & Date – setting current time and date Setting Password – setting system password Brightness – setting LCD brightness Default – change current system parameters to default values Bat Calib – calibration battery voltage

INEX Static Transfer Switch Module

AC Input Voltage Range:	89 to 138Vac for 110/115/120Vac system 176 to 276Vac for 208/220/230/240Vac system
Over Voltage Threshold:	Adjustable between 117 and 127Vac for 110Vac system, default is 121Vac 122 and 132Vac for 115Vac system, default is 127Vac 127 and 138Vac for 120Vac system, default is 132Vac 220 and 240Vac for 208Vac system, default is 229Vac 233 and 252Vac for 220Vac system, default is 242Vac 244 and 264Vac for 230Vac system, default is 253Vac 254 and 276Vac for 240Vac system, default is 264Vac
Under Voltage Threshold:	Adjustable between 89 and 105Vac for 110Vac system, default is 99Vac 93 and 110Vac for 115Vac system, default is 104Vac 100 and 114Vac for 120Vac system, default is 108Vac 176 and 198Vac for 208Vac system, default is 187Vac 176 and 209Vac for 220Vac system, default is 198Vac 185 and 218.5Vac for 230Vac system, default is 207Vac 193 and 228Vac for 240Vac system, default is 216Vac
Redundant Power Supply Design:	Startup power-on by priority source or alternative
Nominal Output Voltage:	Same as utility voltage or inverter output
Permissible Frequency Area:	Max. $\pm 2.5\%$ (inverter synchronization)
Transfer Time:	Typical 1/4 cycle
Rated Power:	50A
Operation Methods:	Inverter priority/Mains priority (On-line/Off-line)

Specifications for INEX Inverter System Continued

Mechanical

Inverter Module:	Dimensions: 43.8mm H x 215mm W x 270mm D [1.7" H x 8.5" W x 10.6" D] Weight: 2.5 kg (5.5 lb.)
STS Module:	Dimensions: 43.8mm H x 215mm W x 270mm D [1.7" H x 8.5" W x 10.6" D] Weight: 2.1 kg (4.6 lb.)
Controller Module:	Dimensions: 43.8mm H x 87.9mm W x 277mm D [1.7" H x 3.4" W x 10.8" D] Weight: 0.5 kg (1.1 lb.)
Interface Module:	Dimensions: 43.8mm H x 129.5mm W x 79.7mm D [1.7" H x 5.1" W x 3.1" D] Weight: 0.25 kg (0.55 lb.)
Inverter Shelf:	Dimensions: 43.8mm H x 440mm W x 329.5mm D [1.7" H x 17.3" W x 13" D] Weight: 2.7 kg (6 lb.)
Controller/Interface/STS Shelf:	Dimensions: 43.8mm H x 440mm W x 329.5mm D [1.7" H x 17.3" W x 13" D] Weight: 2.7 kg (6 lb.)
MBSDU Panel:	Dimensions: 88mm H x 483mm W x 329.5mm D [3.5" H x 19" W x 13" D] Weight: 7.0 kg (15.4 lb.)

Environmental

Operating Temperature:	-20 to +70°C (-4 to +158°F) -5 to +50°C (23 to +122°F) with full performance
Storage Temperature:	-40 to +85°C (-40 to +185°F)
Humidity:	0 to 90% non-condensing
Heat Dissipation:	Forced air cooling for inverter and STS modules
Operating Altitude:	1500m (4922 feet)
Audible Noise:	55dB ETS 300 753 Class 3.1

Standards

Inverter Module:	EN 60950-1, UL-60950-1, IEC 60950-1, CSA C22.2 No. 60950-1
STS Module:	EN62040-1-1, IEC 62310-1, CSA C22.2 No. 107.3, ANSI/UL 1778
Controller Module:	EN 60950-1
Marking:	cULus, CE, RoHS, C-Tick

The above information is valid at the time of publication. Consult factory for up-to-date ordering information. Specifications are subject to change without notice.

IMPORTANT SAFETY INSTRUCTIONS

SAVE THESE INSTRUCTIONS

1. Please read this manual prior to use to become familiar with the product's numerous features and operating procedures. To obtain a maximum degree of safety, follow the sequences as outlined.
2. This manual provides warnings and special notes for the user:
 - a. Points that are vital to the proper operation of the product or the safety of the operator are indicated by the heading: **WARNING**.
 - b. A notation that is in **Bold or Italic** typeface covers points that are important to the performance or ease of use of the product.
3. Before using the product, read all instructions and cautionary markings on the product and any equipment connected to the product.
4. Do not expose the product to rain or snow; install only in a clean, dry environment.
5. **CAUTION** – Unless otherwise noted, use of an attachment not recommended or sold by the product manufacturer may result in a risk of fire, electric shock, or injury to persons.
6. **CAUTION** – Do not operate the product if it has received a sharp blow, it has been dropped, or otherwise damaged in any way – return it to a qualified service center for repair.
7. **CAUTION** – Do not disassemble the product – call our qualified service centers for servicing. Incorrect reassembling may result in a risk of electrical shock or fire.
8. **WARNING** – The input and output voltages of the product are hazardous. Extreme caution should be maintained when servicing or touching conductive components connected to the product.

TABLE OF CONTENTS

1	INTRODUCTION	1
1.1	Scope of the Manual	1
1.2	Product Overview	1
1.3	Model and Part Numbers	2
2	INSPECTION.....	3
2.1	Packing Materials	3
2.2	Check for Damage	3
3	SHELF INSTALLATION	4
3.1	Inverter Shelf Preparation/Mounting	4
3.2	Controller/Interface/STS Shelf Mounting/Preparation.....	6
3.3	MBSDU Panel Mounting/Preparation	7
4	WIRING AND CONNECTIONS	8
4.1	Safety Precautions	8
4.2	Tools Required	8
4.3	Wire Selection	8
4.4	Single Inverter Shelf System.....	9
4.5	Multi-Inverter Shelf System.....	11
4.6	STS/Controller Shelf	14
4.7	Controller/Interface Shelf	15
4.8	MBSDU Panel	17
5	MODULE INSTALLATION AND REMOVAL	20
5.1	Installation and Removal of STS and Inverter Modules.....	20
5.2	Controller Module Implementation	21
5.3	Interface Module Implementation.....	22
6	OPERATION.....	23
6.1	Pre-Operation Check	23
6.2	Status Monitoring	23
6.3	Parameter Setting	25
6.4	Module Parameter Settings	26
7	DEFAULT VALUES	29
8	MAINTENANCE	31
8.1	Inverter Fan Replacement	31
8.2	STS Fan Replacement.....	32
8.3	Replacement Parts.....	32
9	TROUBLESHOOTING.....	33
10	ARGUS CONVENTIONS.....	37
10.1	Numbering System.....	37
10.2	Acronyms and Definitions	37
11	OUTLINE DRAWINGS.....	38
11.1	Mechanical Dimensions of INEX Inverter Module	38
11.2	Mechanical Dimensions of INEX STS Module.....	39
11.3	Mechanical Dimensions of INEX Controller Module	40

11.4 Mechanical Dimensions of INEX Interface Module..... 41
11.5 Mechanical Dimensions of INEX Inverter Shelf 41
11.6 Mechanical Dimensions of INEX Controller/Interface/STS Shelf 42
11.7 Mechanical Dimensions of INEX MBSDU Shelf 43

1 Introduction

1.1 Scope of the Manual

This instruction manual explains the installation, interconnection, and operation of Argus Technologies' INEX Inverter System.

1.2 Product Overview

INEX inverter series is an integrated telecommunication AC power system, including inverter, static switch, LCD controller, and interface modules. With versatile “building block” design and N+1 redundant configuration, INEX inverter system facilitates complex telecommunication and industrial power demands.

INEX series DC to AC inverter module is available for 1000VA (800W) or 1500VA (1200W) to convert -48Vdc input to 120Vac or 230Vac output at 50Hz or 60Hz. The inverter module is “hot swappable” meaning it can be inserted or removed from the shelf without cutting power to or from the system.

A universal 19” shelf is designed to parallel connect and synchronize all INEX inverter models. With this shelf, INEX series employs N+1 redundant configuration to output power maximum of 12kVA for 120Vac models and 18kVA for 230Vac models, and to operate in N+1 redundant mode for optimization. INEX “all master” dynamic mechanisms automatically share and re-organize critical loads to further prevent interruption if one or more inverter modules fail.

INEX selective static transfer switch (STS) provides automatic instantaneous load transfer, which further secures uninterrupted operation of sensitive electronic equipment.

The INEX system controller, equipped with a DSP microprocessor, gives real-time system status through comprehensive LCD/LED indication, and allows program settings through the display panel. A communication interface module provides local or remote control and monitoring of the system.



INEX Inverter system only



INEX Inverter system with control/metering

Illustrations only and may not match your installation.



INEX Inverter system with STS and control/metering



INEX Inverter system with STS, control/metering, and MBS/distribution

Illustrations only and may not match your installation.

INEX Inverter System features include:

- Pure sine wave output with low distortion
- Versatile module design allows a variety of configurations for different power needs
- Easily expands capacity up to 18kVA with N+1 redundancy
- “All master” dynamic mechanism eliminates single-point failure to optimize reliability
- Hot-pluggable connection allows module addition or removal without cutting power
- Ultimate high power density reducing space demand
- High efficiency (> 88%)
- Comprehensive LCD/LED display provides system status, and user-friendly panel eases program settings.

1.2.1 WinPower Software

WinPower is a power management software specifically designed to monitor and control the INEX inverter system via a personal computer. It is available to download via the Argus website (www.argusdcpower.com).

To remotely monitor and control INEX inverters, connect the USB cable (A-B type) to the port on the front panel of the interface module. Then follow instructions stated in the WinPower manual to properly install the software to a personal computer physically connected to the INEX inverter system.

1.3 Model and Part Numbers

This product is available to order under the following part numbers:

Model Number	Description	Part Number
INV-4810A	1000VA/800W inverter module (I/P: 48Vdc, O/P: 120Vac, 60Hz).....	014-114-10
INV-4810EA	1000VA/800W inverter module (I/P: 48Vdc, O/P: 230Vac, 50Hz).....	014-115-10
INV-4815A	1500VA/1200W inverter module (I/P: 48Vdc, O/P: 120Vac, 60Hz).....	014-116-10
INV-4815EA	1500VA/1200W inverter module (I/P: 48Vdc, O/P: 230Vac, 50Hz).....	014-117-10
MC-1000A	Controller module.....	018-593-10
STS-050A	50A static transfer switch module.....	019-050-10
MBSDU-50-2U-19A	Discontinued, see 020-424-10.....	020-417-10
MBSDU-50-2U-19-UA	MBS+DU panel (maintenance bypass switch and NEMA AC distribution).....	020-422-10
MBSDU-50-2U-19A	MBS+DU panel (maintenance bypass switch and IEC AC distribution).....	020-424-10
INVSS-2EA-1U-19A	Inverter shelf.....	030-419-10
STSSS-I-1EA-1U-19A	Controller/STS shelf (includes interface module IFC-1000NSA).....	030-420-10
MC-BLANK	Controller blank plate.....	614-616-10
IFC-BLANK	Interface blank plate.....	614-617-10
INV-BLANK	Inverter/STS blank plate.....	614-618-10

The above information is valid at the time of publication. Consult factory for up-to-date ordering information.

2 Inspection

2.1 Packing Materials

All Argus products are shipped in rugged, double walled boxes and suspended via solid inserts to minimize shock that may occur during transportation. Packaging assemblies and methods are tested to International Safe Transit Association standards.

Power systems are also packaged with Cortex. This plastic wrap contains a corrosive-inhibitor that protects the product from corrosion for up to two years.

2.1.1 Returns for Service

Save the original shipping container. If the product needs to be returned for service, it should be packaged in its original shipping container. If the original container is unavailable, make sure the product is packed with at least three inches of shock-absorbing material to prevent shipping damage.

NOTE: *Argus Technologies is not responsible for damage caused by the improper packaging of returned products.*

2.2 Check for Damage

Prior to unpacking the product, note any damage to the shipping container. Unpack the product and inspect the exterior for damage. If any damage is observed contact the carrier immediately.

Continue the inspection for any internal damage. In the unlikely event of internal damage, please inform the carrier and contact Argus Technologies for advice on the impact of any damage.



Verify that you have all the necessary parts per your order for proper assembly.

3 Shelf Installation

This chapter is provided for qualified personnel to install the product.

3.1 Inverter Shelf Preparation/Mounting

The inverter shelf has been designed for flush or mid-mounting in a 19" relay rack. Mounting brackets are also supplied for mounting in a 23" rack.

NOTE: *The shelf shall be mounted in a clean and dry environment. Allow at least 1.75" of free space in front of the unit for unrestricted cooling airflow.*

1. There are four holes right above three deck connectors of each inverter slot. Based on inverter model, insert the supplied nylon guide pin to the corresponding hole:
 - Position A for INV-4815A (as shown below)
 - Position B for INV-4815EA
 - Position C for INV-4810A
 - Position D for INV-4810EA

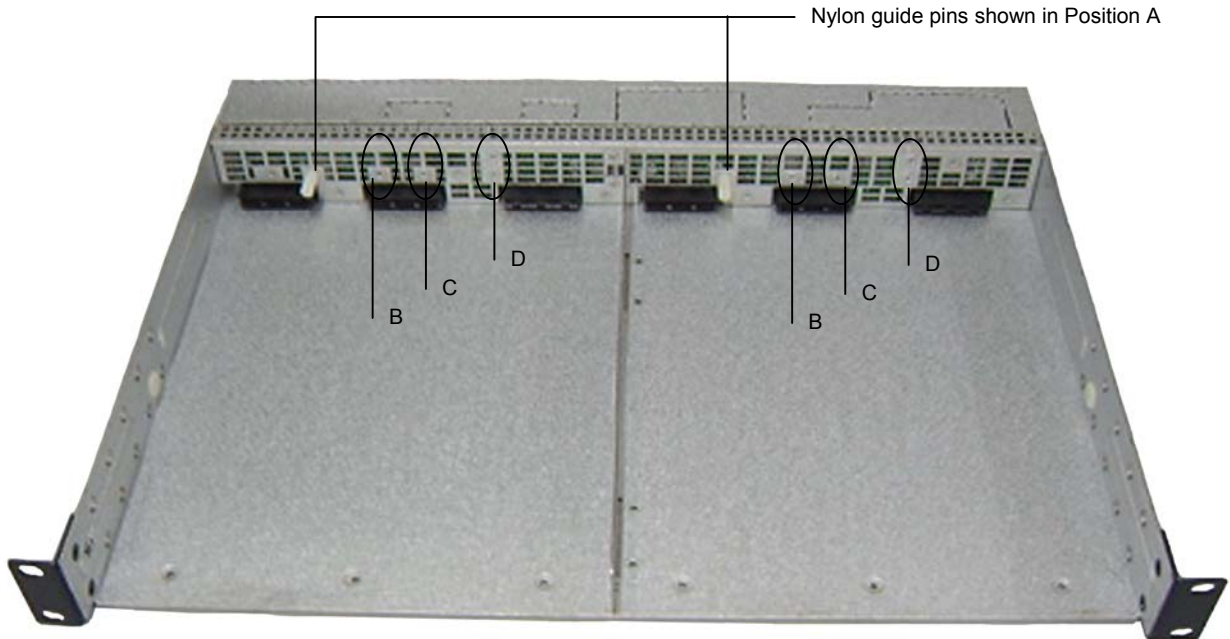

CAUTION

System will fail to operate normally when inverter modules of different specifications are inserted into inverter shelves. Use supplied nylon guide pins for securing only inverter modules of the same specifications.

2. The shelf should be mounted to the rack using at least two #12 – 24 x 1/2" screws in each bracket. Philips-type screws and screwdriver should be used to eliminate the possibility of slippage and scratching of the unit's exterior. Washers (such as internal tooth) or special screws that are designed to cut through the painted surface should be used to ensure a good chassis ground.
3. Put the inverter shelf into the equipment rack horizontally, and align holes of mounting brackets and rack.



4. Each inverter shelf holds maximum two inverter modules. Repeat the steps above to install the inverter shelves as required.

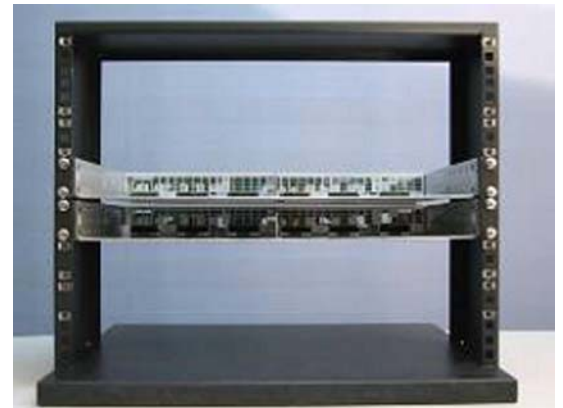

5. All input and output connections are made through the knockouts, located in the top and the bottom of the shelf rear cover, as well as both side panels. Remove the rear cover to access the inverter shelf backplane and connectors.



6. Knockouts on top and bottom are for shelf inter-connections and supplementary wire routing. To remove knockout, snip tabs, move plate up and down until tabs in back snap apart.



3.2 Controller/Interface/STS Shelf Mounting/Preparation

The shelf has been designed for flush or mid-mounting in a 19" relay rack. Mounting brackets are also supplied for mounting in a 23" rack.

NOTE: *The shelf shall be mounted in a clean and dry environment. Allow at least 1.75" of free space in front of the unit for unrestricted cooling airflow.*

1. The shelf should be mounted to the rack using at least two #12 – 24 x 1/2" screws in each bracket. Philips-type screws and screwdriver should be used to eliminate the possibility of slippage and scratching of the unit's exterior. Washers (such as internal tooth) or special screws that are designed to cut through the painted surface should be used to ensure a good chassis ground.
2. Put the shelf into the equipment rack horizontally, and align holes of mounting brackets and rack.



NOTE: *Each INEX controller module or interface module allows maximum control of 12 inverter units cascaded. It is recommended to have the controller/interface/STS shelf installed on top of stacked inverter shelves to ease inter-connections; however, it may be installed below the inverter shelves if the MBSDU panel is not required.*



All input and output connections are made through the knockouts, located in the top and the bottom of each of the two rear covers, as well as both side panels. The cover on the right is for the controller/interface section, and the cover on the left is for the STS section.

3. Remove the rear cover(s) to access the shelf backplane and connectors.
4. Knockouts on top and bottom are for shelf inter-connections. To remove knockout, snip tabs, move plate up and down until tabs in back snap apart.



3.3 MBSDU Panel Mounting/Preparation

The panel has been designed for flush or mid-mounting in a 19" relay rack. Mounting brackets are also supplied for mounting in a 23" rack.

NOTE: *The panel shall be mounted in a clean and dry environment.*

1. The panel should be mounted to the rack using at least two #12 – 24 x 1/2" screws in each bracket. Philips-type screws and screwdriver should be used to eliminate the possibility of slippage and scratching of the unit's exterior. Washers (such as internal tooth) or special screws that are designed to cut through the painted surface should be used to ensure a good chassis ground.



2. Put the panel into the equipment rack horizontally, and align holes of mounting brackets and rack. The panel must be mounted above the controller/interface/STS shelf.



3. All input and output connections are made through the knockouts, located in the bottom of the rear cover and both side panels. To remove knockout, snip tabs, move plate up and down until tabs in back snap apart.

4. Remove the rear cover to access the backplane and connectors.



4 Wiring and Connections

This chapter provides notes on cable sizing and cabling details with respect to the Argus INEX 1000/1500 Inverter System.

4.1 Safety Precautions



WARNING

Ensure all power sources are OFF during wiring. Disconnect battery cables from battery.

Before working with any battery or power system/distribution center, follow these precautions:

- Remove all metallic jewelry; e.g., watches, rings, metal rimmed glasses, necklaces.
- Wear safety glasses with side shields (and prescription lenses if necessary) at all times during installation.

The installer should follow all applicable local rules and regulations for electrical and battery installations; e.g., CSA, UL, CEC, NEC, OSHA, and local fire codes.

Use OSHA approved insulated hand tools.

4.2 Tools Required

Various tools are essential for product installation. Use this list as a guide:

- Slot head screwdrivers (blade sizes: 1/4", 1/8", 1/16")
- Philips head screwdriver, #2 (tip size 3/16")
- Digital voltmeter equipped with test leads
- Adjustable 48Vdc load (optional)
- Cutters and wire strippers
- Crimping tool (optional for large gauge wire)
- Anti-static wrist strap.

4.3 Wire Selection

The INEX inverter modules are designed to operate in parallel for higher output current. Two modules are automatically connected in parallel in each shelf. Two or more inverter shelves can be further connected in parallel for additional output power; this is done by connecting inputs (BAT-, BAT+) in parallel, and outputs (Line, Neutral, Ground) in parallel. When paralleled, there is no master unit and each unit adjusts its own power level for best power sharing. Please refer to the following wiring instructions for your needs.

When selecting wiring, consider the following factors:

- Current carrying capacity of the wire
- Maximum wire length needed
- Maximum ambient temperature.

NOTE: Use the following table as a guide only. Ensure that the installation complies with the specific wiring rules applicable to your country or area of jurisdiction.

Shelf number of 2 x 1000VA inverter cascaded	Input Current Maximum @ 40Vdc	110Vac Output Current Max.	230Vac Output Current Max.	Minimum Size of DC Input Wire Max.	Min. Size of 110Vac Output Wire Max.	Min. Size of 230Vac Output Wire Max.
#1	45.5A	18.2A	8.7A	#8 AWG	#14 AWG	#16 AWG
#2	91.0A	36.4A	17.4A	#4 AWG	#10 AWG	#14 AWG
#3		54.5A	26.1A		#8 AWG	#10 AWG
#4		72.7A	34.8A		#6 AWG	#10 AWG
#5		90.9A	43.5A		#4 AWG	#8 AWG
#6		109.1A	52.2A		#3 AWG	#8 AWG

Shelf number of 2 x 1500VA inverter cascaded	Input Current Maximum @ 40Vdc	110Vac Output Current Max.	230Vac Output Current Max.	Minimum Size of DC Input Wire Max.	Min. Size of 110Vac Output Wire Max.	Min. Size of 230Vac Output Wire Max.
#1	68.2A	27.3A	13.0A	#6 AWG	#12 AWG	#16 AWG
#2	136.4A	54.5A	26.1A	#2 AWG	#8 AWG	#12 AWG
#3		81.8A	39.1A		#6 AWG	#10 AWG
#4		109.1A	52.2A		#3 AWG	#8 AWG
#5		136.4A	65.2A		#2 AWG	#6 AWG
#6		163.6A	78.3A		#2 AWG	#6 AWG

Table A—Recommended wire size versus current

Remarks: 1. Total Power Rating (VA, W) = No. of shelf × Inverter module power rating (VA, W) * 2
 2. I/P current = Total power rating (W) ÷ 0.88 ÷ 40
 3. O/P current = Total power rating (VA) ÷ AC voltage

4.4 Single Inverter Shelf System

1. In the inverter shelf package, you will find a jumper. When only ONE inverter shelf is applied in the system, insert the jumper to pins 1 and 2 of connector JP2:

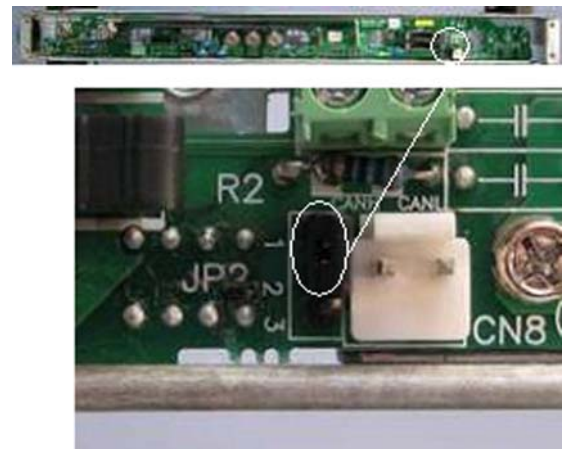

2. Negative (BAT-) and positive (BAT+) DC input terminal studs are located in the left side of backplane. In consideration of the power rating and distance from the battery, choose appropriate gauge wire using Table A as well as local wiring rules.

NOTE: For inverter systems without a controller, open collector terminals are available on the inverter shelf backplane for the inverter fail alarm. See details under point 9 of Section 4.5.

3. Thread battery cables through left-side panel knockout; put the hole lug at one end of each battery cable to DC input stud.

4. Secure the connection with two supplied M5x12 cross hex-washer nickel screws and washers as shown:

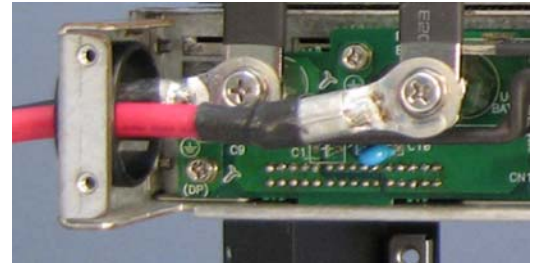

CAUTION

Reverse polarity connections would damage the unit and is not cover by the warranty. Ensure correct polarity (positive to positive, negative to negative) before completing connections between battery and INEX inverter unit.

5. Install the other end of battery cables to battery or 48Vdc source.



WARNING

DC source voltage should be between 45V and 58V.

6. The three studs in the center of the backplane are AC output terminals. AC neutral, ground and line are marked as UC3, UC4 and UC5, respectively. Check the AC output voltage. Using Table A, as well as local wiring rules, choose appropriate gauge wire.
7. Thread AC neutral and line wires through left-side panel knock-out, put the hole lug at one end of each wire to AC neutral and AC line studs.
8. Secure the connection with two supplied M5x12 cross hex-washer type nickel screws and washers as shown.
9. Install the other end of wires to the AC distribution or load.

10. AC Ground stud (UC4) is mainly for inter-connection with extra shelves. To do system grounding, cover up the backplane with the rear cover first, and screw the ground wire on the rear cover with the supplied cross hex-washer type nickel screw as shown:

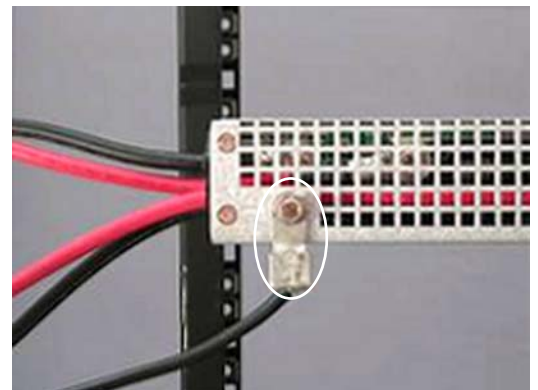

DANGER

To meet CEC/NEC requirements – to prevent fire, electric shock, improper operation of circuit protection devices, as well as improper operation of the equipment – an electrical bond between neutral and ground is required at the AC source or distribution point of an inverter system.

Ensure that the installation complies with the specific wiring rules applicable to your country or area of jurisdiction.

4.5 Multi-Inverter Shelf System

CN20 and CN21 at the inverter shelf backplane are inter-parallel connectors for inverter synchronization. The upper port is used to connect the inverter shelf above, and the lower port is used to connect the inverter shelf below.



1. Use the flat communication cables provided to connect all available inverter shelves:

2. Use the supplied bus bars for connecting the DC negative input (BAT-) studs of all available shelves together with M5x12 cross hex-washer type nickel screws and washers. See Table A.
3. Similarly, connect DC positive input (BAT+) studs of all shelves together.
4. Do the same for AC neutral (UC3), AC ground (UC4) and AC line (UC5) studs individually:

NOTE: Spacers supplied are required on the last (bottom) shelf for AC bars.

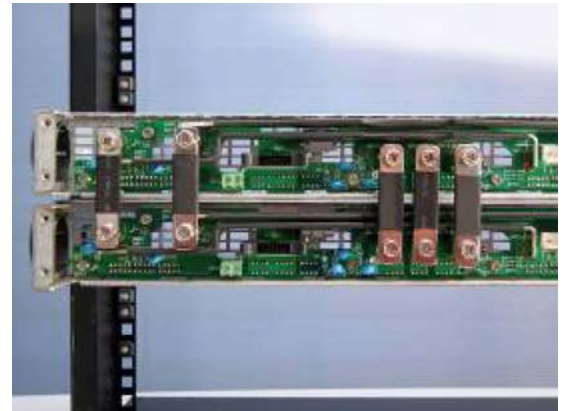
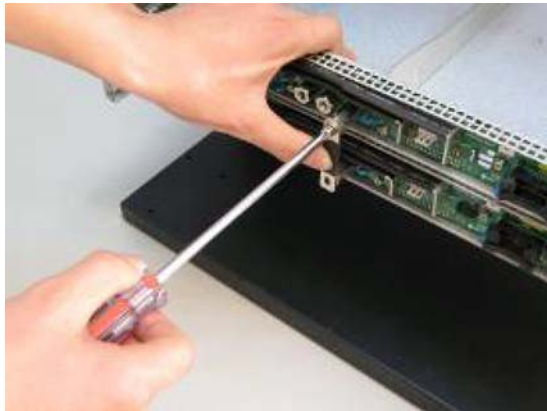

CAUTION

Ensure that no jumper is inserted into JP2 connector of all connected inverter shelves.

5. Choose appropriate gauge wire with consideration for the total input current of the whole inverter system, distance from the battery, and local wiring rules.
6. Thread two battery cables through left-side panel knockout, and attach one battery cable to one DC negative input stud (BAT-) and the other to one DC positive input stud (BAT+).



CAUTION

Reverse polarity connections would damage the unit and is not cover by the warranty. Ensure correct polarity (positive to positive, negative to negative) before completing connections between battery and INEX inverter unit.

7. Secure the connection with two supplied cross hex-washer type nickel screws and washers as shown.
8. Install the battery cables to battery or 48Vdc source.



WARNING

DC source voltage should be between 45V and 58V.

9. For inverter systems without a controller, open collector terminals are available on the inverter shelf backplane for the inverter fail alarm.
10. Check the AC output voltage. Using Table A, as well as local wiring rules, choose appropriate gauge wire.
11. Thread selected AC neutral and line wires through left-side panel knockout, and attach one cable to one AC neutral (UC3) stud and the other to AC line (UC5) stud.
12. Secure the connection with two supplied M5x12 cross hex-washer type nickel screws and washers.
13. Install the other end of wires to the AC distribution or load.

To connect the INEX inverter with an Argus Cordex™ system controller (CXC), use the contacts of CN11 on the INEX inverter shelf to connect to any available digital input on the CXC. See the following example:

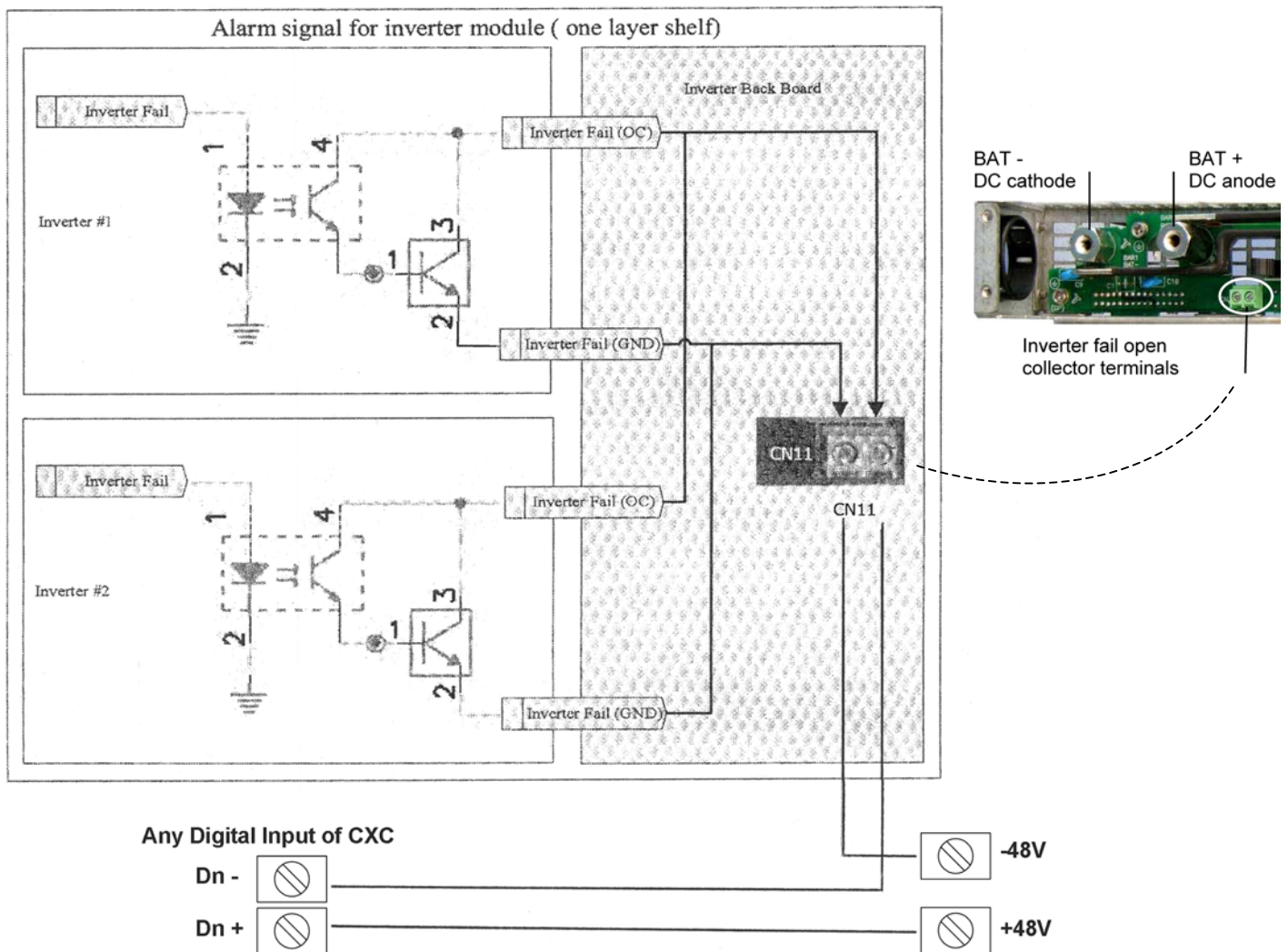

14. To do system grounding, cover up the backplane with the rear cover first, and screw the ground wire on the rear cover with the supplied cross hex-washer type nickel screw as shown:



NOTE: *INEX inverter modules allow maximum 12 units cascaded for expanding power capacity. The input current of entire inverter system would exceed the current limit of available wires. When the total input current is over the cable current limit, split DC connection to multiple groups by removing inter-connected BAT+ & BAT- bus bars between groups, and choose suitable wire size for each group. Input DC feeder breaker configured one per shelf or optionally input breaker per two shelves maximum.*

4.5.1 CASE STUDY – An inverter system with eight INV-4810A inverter modules (8kVA)

The total input current, 151.5A @ 48Vdc, can be halved by removing DC positive (BAT+) and DC negative (BAT-) bus bars connected between shelves 2 and 3. DC connection is split into two groups (4kVA and 4kVA). After selecting suitable wire for minimum transmission current of 75.8A, two pairs of battery cable are separately connected to DC positive and negative studs of both groups as shown:

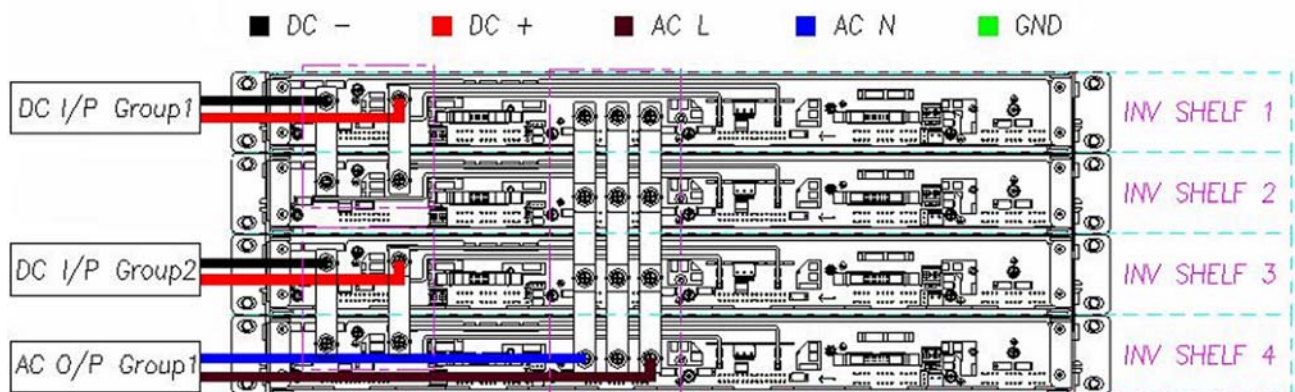

4.6 STS/Controller Shelf



WARNING

Ensure all power sources are OFF during wiring. Disconnect battery cables from battery.

1. Follow wiring instructions to suit your installation.

CN1: Use shorting plug for pins 1 to 4 when MBS is not installed

CN2: SYNC port on the controller/interface shelf backplane

2. Locate the CN2 connector on the backplane of the STS shelf and the CN7 connector on the backplane of the inverter shelf. Connect these two connectors with the attached STS signal cable as shown:

CN7: SYNC port on the inverter shelf backplane

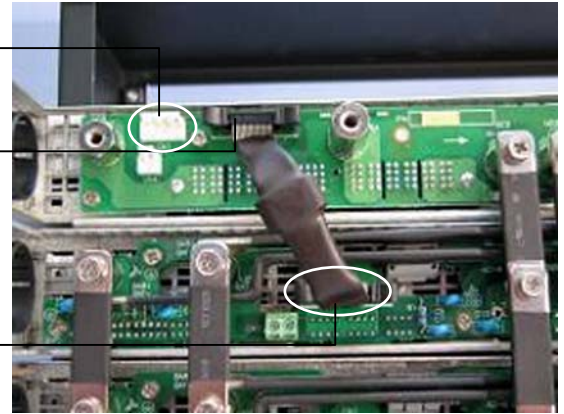

3. Connect AC bus connectors of STS shelf to the AC bus of the top level inverter shelf.
4. Then connect the AC bus connectors between inverter shelves.

NOTE: Spacers supplied are required on the last (bottom) shelf for AC bars.

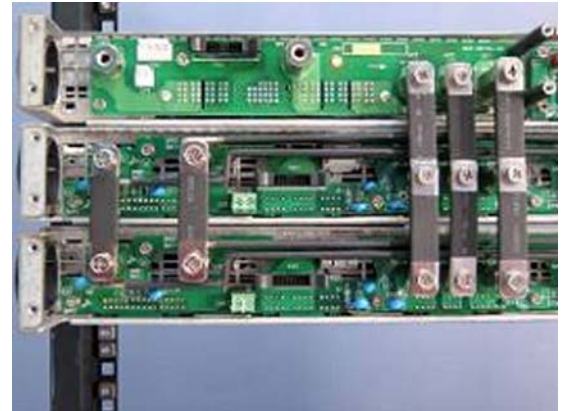

5. Route both DC input wires through the wire hole on the left side of the inverter shelf. Use the cross-pan type nickel screws in accessory kit for fixing both DC input wires.

CAUTION

To connect AC output wires onto the system, only one AC line and AC neutral are necessary to be connected either from STS shelf or inverter shelf.

6. **For inverter shelf only or without STS module:**
Connect AC LINE to the UC4 (AC-L OUT) connector of STS shelf.
Connect AC NEUTRAL LINE onto UC3 (AC-N) connector of STS shelf.
7. **With STS module:**
Connect AC LINE IN to UC5 and AC LINE OUT to UC4 of STS shelf. Connect AC NEUTRAL IN/OUT to UC3.

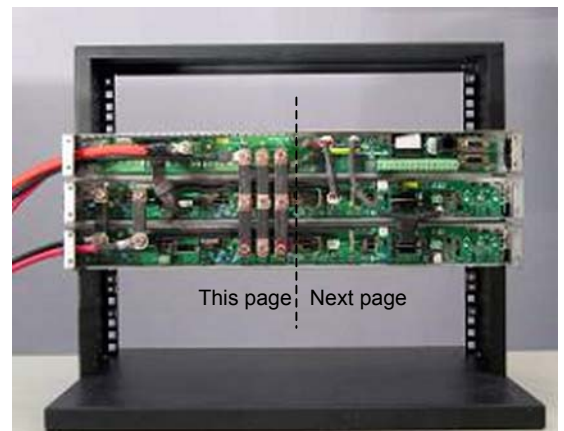

4.7 Controller/Interface Shelf



WARNING

Ensure all power sources are OFF during wiring. Disconnect battery cables from battery.

1. INEX controller and interface modules are powered from inverters. Securely plug one end of the supplied 3-pin power cable to CN12 power jack on the controller/interface/STS shelf backplane, and the other end to CN9 power jack on the inverter shelf backplane:

CN12: Power connector of controller

CN9: Power connector to controller

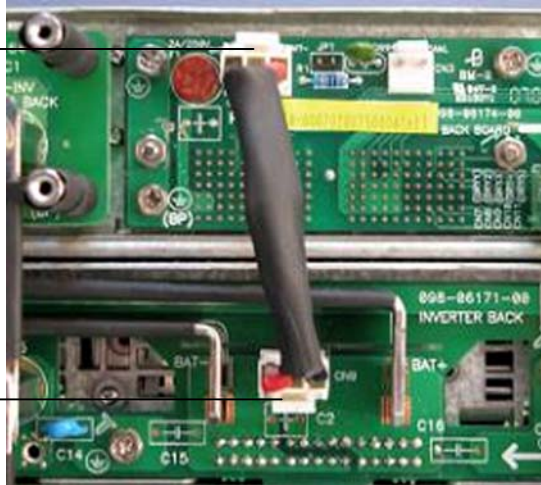

2. CN3 connector on the controller/interface shelf backplane, and CN8 connector on the inverter shelf backplane are for data transferring between controller/interface modules and inverters. Use the supplied signal cable to link the two connectors together as shown:

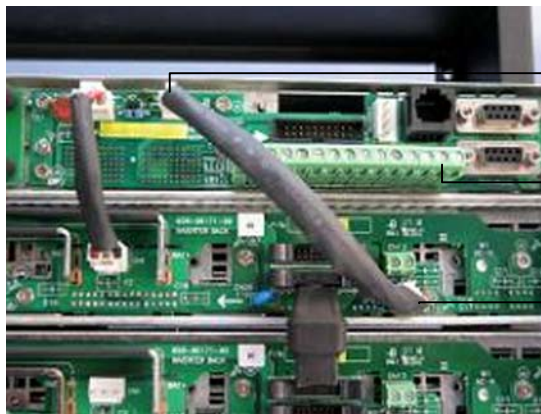

CN3: CAN COM port on the controller/interface shelf backplane

CN7 to CN11 relay alarm contacts (1A rated) [see below]

CN8: CAN COM port on the inverter shelf backplane

- Use #30 to 16AWG to connect dry contact terminal CN7 to CN11:

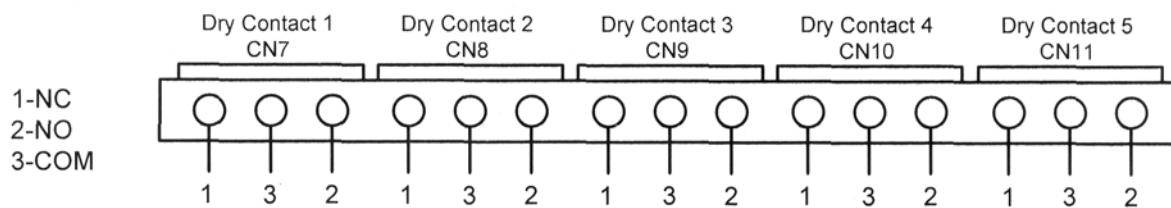
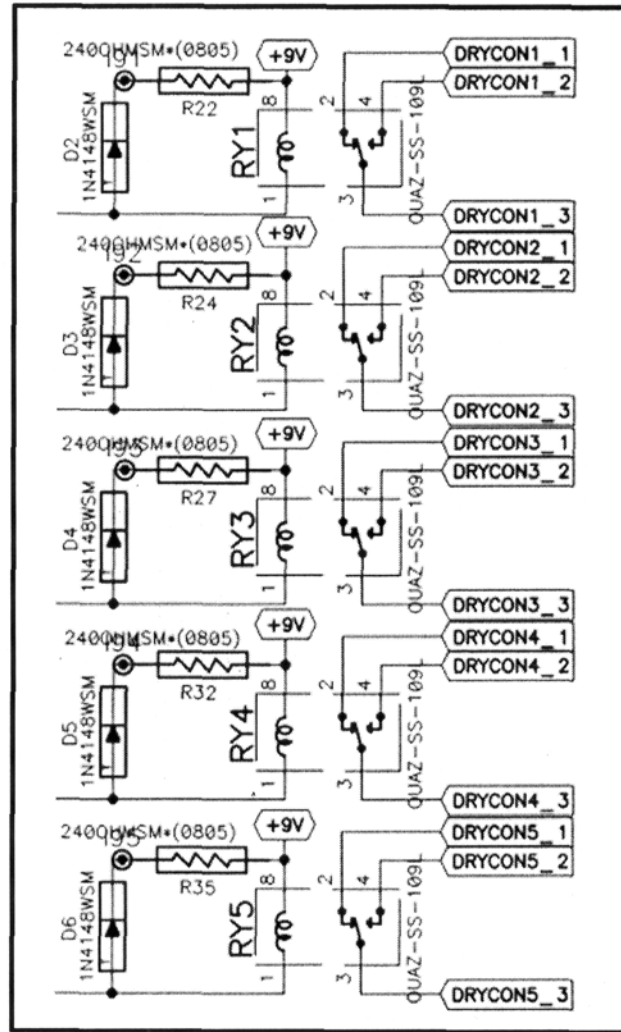

NOTE: To set the alarm mode of dry contact, refer to the next chapter.

- Replace rear cover(s) once all connections have been completed.

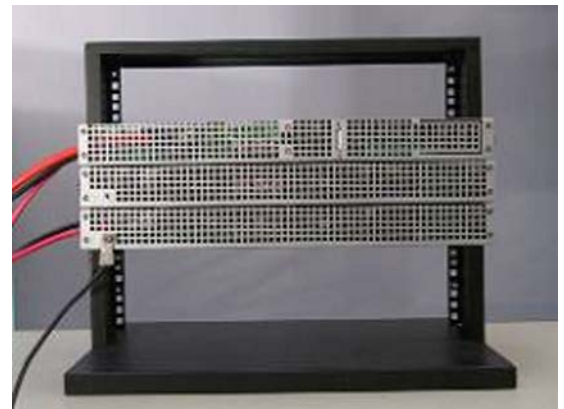

4.8 MBSDU Panel

1. Connect signal cables between MBSDU panel, STS and inverter shelves as shown:
2. Remove the shorting plug on CN1 and connect the 4-pin MBS cable to the CN1 connector on the backplane of the STS shelf.



3. Connect the 5 bus bars supplied with the MBSDU panel to the STS backplane via the corresponding connectors of MBSDU panel as shown:

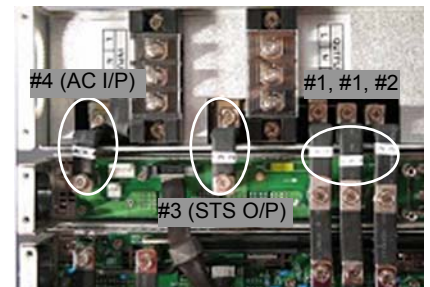

DANGER

To meet CEC/NEC requirements – to prevent fire, electric shock, improper operation of circuit protection devices, as well as improper operation of the equipment – an electrical bond between neutral and ground is required at the AC source or distribution point of an inverter system.

Ensure that the installation complies with the specific wiring rules applicable to your country or area of jurisdiction.

For INEX systems with a MBSDU, this can be facilitated by installing a wire jumper between Neutral and Ground on the terminal block labelled “output” on the back of the MBSDU shown here:

4. Connect AC input to the terminal on the back left of MBSDU panel according to the position of the labels as shown.

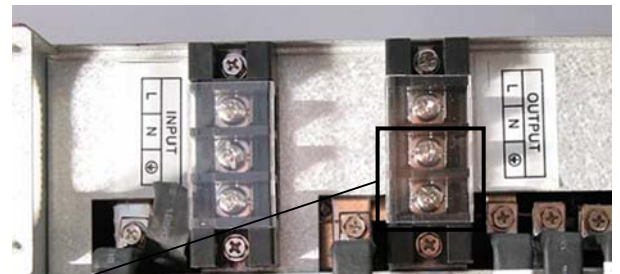

Wire jumper should be sized for the maximum capacity of the system. Refer to Table A.

5. Connect AC output to the terminal (according to the label) on the back right of MBSDU panel to external distribution or load.



6. Replace rear cover(s) once all connections have been completed.
7. Screw the system ground wire on the rear cover with the supplied cross hex-washer type nickel screw.



CAUTION STS is not hot swap without MBS.

When installing STS module with MBS it is not necessary to turn off the system. However, the incorrect install/removal action will damage the STS module frame because of the safety lock of the MBS.

Proceed as follows: put switch at MBP or IBP position (Determined by mains and inverter output status) as shown:

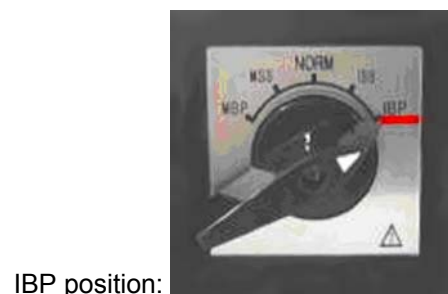
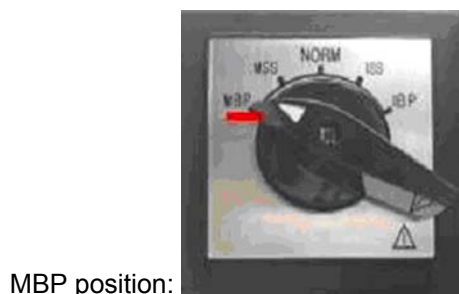

4.8.1 Position Status of MBS

The operation mode of STS is closely associated with the position of MBS. The MBS has two main connectors and three assistant connectors. The signals generated by three assistant connectors are passed to DSP for position status detection. There are five valid positions:

1. MBP – mains bypass
2. MSS – mains static switch (for mains maintenance)
3. NORM – normal operation
4. ISS – inverter static switch (for inverter maintenance)
5. IBP – inverter bypass

STS will continuously detect the position of MBS in order to decide the transferring action between different modes.

When the STS is powered on, it will judge whether the present position of MBS is valid. If the status is invalid, STS will consider MBS not well connected, and it will not enter any types of operation mode until the detection signal becomes normal.

If MBS is changed when STS runs at one of the five valid positions, and this change happens between two adjacent positions, the STS will transfer to different mode based on current status. Otherwise, the STS will not take any action.

For example, if MBS is set at P3, STS will take action when MBS is turned to P2 or P4.

MBS Position	Postural Plot	Function Description	Power Source
Mains Bypass (MBP)		Load is powered through the MBS by the Mains AC. STS can now be removed from the system.	Mains AC power the load via MBS contact 1.
Mains Static Switch (MSS)		Mains AC power the load. Inverters are ON, but do not provide any load power. Inverter tests can be made.	Mains AC power the load.
Normal Operation (NORM)		Usually, the system will work with MBS staying at this position, only at this position that the load can get power from either Mains AC or inverter, the transfer action between Mains AC and inverter can only take place at this position	The system output can get power from either Mains AC or Inverter according to the programmable priority.
Inverter Static Switch (ISS)		Mains AC are disconnected from the system. This is achieved by opening the Backfeed contactor.	Inverter powers the load.
Inverter Bypass (IBP)		Load is powered through the MBS by the Inverters. STS can now be removed from the system.	Inverter powers the load via MBS contact 2.

NOTE: Be sure not to change MBS position immediately when STS is inserted into the rack, wait at least five seconds if you want to change it. When you change its position you must confirm that you keep MBS at one position more than one second in order for MCU of STS has enough time to detect MBS position via MBS auxiliary contacts (CN1).

5 Module Installation and Removal

5.1 Installation and Removal of STS and Inverter Modules

1. Install the inverter or STS module by sliding it into a pre-wired rack mount shelf until the faceplate is flush with the mounting ears.
2. In order to prevent the inverter or STS module removal, turn the lock bolt counter-clockwise to LOCK position.

CAUTION

Parallel connection of inverter modules with different specifications would lead to serious damage, and is not covered by the warranty. Use supplied nylon guide pins for securing only inverter modules of the same specifications.



Inverter shelf holds only inverter modules; STS module will not fit in an inverter shelf.

3. Each inverter shelf holds maximum two inverter modules. Repeat previous steps to insert inverter module to inverter shelf as required.
4. Inverter or STS module can be removed by pulling on the handle after turning the lock bolt to the UNLOCK position. **CAUTION: STS is not hot swap without MBS.**
5. You can cover the excess cavity with an optional blank plate as follows:
The optional cover plate comes into two pieces: orthogonal silver metal piece and black coated cover plate.



6. After screwing the inner silver metal piece to the shelf bottom plate, use bolts on both sides to attach the black metal cover to the inner silver piece.

7. If controller module and/or interface module is not required, you can cover the excess cavity of controller/interface/STS shelf with optional blank plates. The optional blank plate comes into two pieces.
8. After screwing the inner silver metal piece to the shelf bottom plate, use bolts on both sides to attach the black metal blank plate to the inner silver piece.

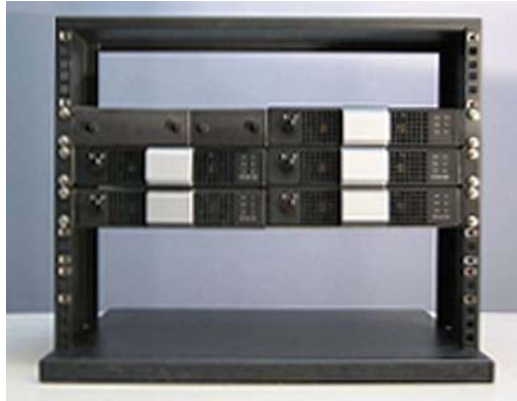

5.2 Controller Module Implementation

1. To install the controller module, slide it into the 2U-wide controller slot of the pre-wired controller/interface/STS shelf until the faceplate is flush with the mounting ears. With the power on, the green LED of the controller unit will light if everything functions correctly.



2. If an interface module is available, simply insert the interface module into the 3U-wide interface slot of the pre-wired controller/interface/STS shelf until the faceplate is flush with the mounting ears.



5.3 Interface Module Implementation

NOTE: IFC is pre-installed on the 030-420-10 shelf.

1. To install interface module, the rear cover must be removed.
2. Plug one end of the supplied flat cable to CN1 connector, and route the other end through the hole on the controller/interface/STS shelf backplane as shown.
3. Cover up the controller/interface shelf backplane with the rear cover.



4. Pull the other end of flat cable to the front of INEX inverter system, and plug the cable to the cable socket on the interface module PCB shown below:

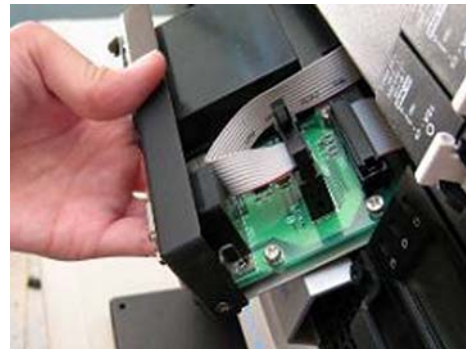

6 Operation

6.1 Pre-Operation Check

6.1.1 Inverter Operation Check

- Check the DC input polarity.
- Ensure the input voltage is in the standard range.
- Check wiring size based on local codes and the wiring table.
- Ensure the rear cover is securely installed for safety; preventing electrical shock.
- Ensure the ground wiring is properly connected on rear cover for safety; preventing electrical shock.
- Ensure the inverter module has been locked. The lock bolt should be in the lock position.

At power on, the inverter/STS unit enters into a self-diagnostic mode with POWER ON and WARNING LED indicators blinking simultaneously. If everything functions correctly, the ON indicator will remain solid green, and the power will be delivered to the AC output terminals.

6.1.2 STS Operation Check

- If installed, ensure the MBS is at “Normal” position.
- Ensure the rear cover is securely installed for safety; preventing electrical shock.
- Ensure the STS module has been locked. The lock bolt should be in the lock position.

6.1.3 Controller/Interface Operation Check

- Ensure the controller module is securely installed.
- Ensure the rear cover of controller/interface/STS shelf is securely installed.
- Ensure the interface module is securely installed and the wiring is properly connected.

6.1.4 MBS Operation Check

- The breakers are at ON position.
- The rear cover of MBS is securely installed.

6.2 Status Monitoring

When the controller module is properly installed with power on, the LCD screen will light by displaying “Waiting” for self-diagnosis. Within a few seconds, STATUS and SETTING options will then show on the screen.



STATUS is classified into four sections: MODULE, CONTROLLER, BATTERY, and ALARM.



Heading	Value
Address	Inverter module location
Serial No	Serial number of the selected inverter module
OPV	Output voltage of the selected inverter module in Volts (V)
OPI	Output current of the selected inverter module in Ampere (A)
OPF	Output frequency of the selected inverter module in Hertz (Hz)
OPP	Power capacity of the selected inverter module in Volt-Amperes (VA)
IPV	DC input voltage of the inverter system in Volts (V)
Power Used	Load level in percentage (%)
Heatsink	Inverter system temperature in Celsius (°C)
Ambient Temp.	Inverter ambient temperature in Celsius (°C)
Run time	Inverter running time in hour (H)
Power Limited	Power limited in percentage (%)
HW Rev	Hardware version of the selected inverter module
SW Rev	Software version of the selected inverter module

Table B–LCD display of inverter status

Heading	Value
Address	STS module location
Serial No	Serial number of installed STS module
OPV	Output voltage of STS module
OPI	No display
OPF	Output frequency of STS module
OPP	No display
Mains AC Vol	Voltage of AC connected to STS module
Main AC Freq	Frequency of AC connected to STS module
INV AC Volt	Voltage of Inverter AC connected to STS module
INV AC Freq	Frequency of Inverter AC connected to STS module
MBS Position	Current MBS position (IBP /ISS/Normal/MSS/MBP)
Running Mode	STS current running mode (Inverter/mains/standby/power on)
Default Volt	STS default output voltage (V)
Default Freq	STS default output frequency (Hz)
Power Used	Load level in percentage (%)
Temperature	STS temperature in Celsius (°C)
Run Time	STS running time in hour (H)
Priority Mode	Operation mode of STS module; ON = output from inverter, OFF = output from AC STS, the default is ON
HW Rev	Hardware version of STS module
SW Rev	Software version of STS module

Table C–LCD display of STS status

Heading	Value
Hardware Version	Hardware version of controller module
Firmware Version	Software version of controller module
Input Voltage	DC input voltage of controller module in Volts (V)
Temperature	Controller temperature in Celsius (°C)

Table D–LCD display of controller status

Main menu->Alarm->Active Alarm		
Item	Specification	Remark
Inverter	Serial number, Alarm name, Event time	For example: <div style="border: 1px solid black; padding: 5px; width: fit-content;"> 1. Inv xxxxxxxxxx Fan Fault yyyy-mm-dd hh:mm:ss ▼ </div>
STS	Serial number, Alarm name, Event time	
SMR (N/A)	Serial number, Alarm name, Event time	

Table E–LCD display of alarm log

6.3 Parameter Setting

INEX inverter system allows some parameters to be adjusted through the controller module.

1. Use PgDn▼ key and Enter ⏪ key to select SETTING.
2. A four-digit numeric password is required. Use PgUp▲ key to increase number, and PgDn▼ key to decrease number.

For example, press PgUp▲ key once for 1, twice for 2, three times for 3, and so on.

3. Press Enter ⏪ to validate each digit of the password once the desired number is selected.
The default password is 1234.



No setting modification can be executed if a wrong password is entered.



SETTING section is divided into two categories: MODULE and SYSTEM.

Parameters of modules can be modified or adjusted under MODULE while system-related setups can be done under SYSTEM. The following sections refer to detailed setup procedures.

NOTE: To activate system level changes, cycle the system power off then on again.

6.3.1 Password Setting

A new password can be set in SYSTEM option under SETTING.

1. Press Enter ⏪ key to enter SETTING PASSWORD menu for resetting the password.
2. Use PgUp▲ key and PgDn▼ key to select a number.
3. Press Enter ⏪ to validate each digit of the password once the desired number is selected.
4. After the new four-digit password is input, the system will prompt the user to re-enter the new password as confirmation. Input the new password again.

Once the password is successfully changed, DONE will appear on the screen.

6.3.2 Inverter System Parameter Settings

Parameter	Specification
BaudRate: Baud rate of COM port	Selectable at 1) 2400bps, 2) 4800bps and 3) 9600bps
RS422 Addr: RS422 address	RS422 communication protocol
Keypad tones: activation or de-activation of audio alarm	Selectable at 1) Enable and 2) Disable
Time&Date: Time and Date displayed on LCD	Time: hh:mm:ss Date: yyyy-mm-dd
Language	English
Brightness: LCD brightness	From 00~63 for adjusting LCD display contrast
Default: Reset Default value	Press "Enter" for resetting the default value and "ESC" cancel the setting Reset to Default Value (refer to Appendix A)
Dry Connect: Dry contact setting	Refer to Module Parameter Settings section: Dry Contact Setting
Bat Calib: battery voltage calibration	xx.xxV For regulating the battery voltage value of LCD display of controller after operating for long period of time. The adjustable range is from 20.01V to 69.99V

Table F–System parameter settings

6.4 Module Parameter Settings

Parameter	Setting Option
Output volt: Inverter output voltage	For INV-4810EA/INV-4815EA, selectable at: 1) 208Vac 2) 220Vac 3) 230Vac 4) 240Vac For INV-4810A/INV-4815A, selectable at: 1) 110Vac 2) 115Vac 3) 120Vac
Output Freq: Inverter output frequency	Selectable at 1) 50Hz and 2) 60Hz
OPV HL: High loss of inverter output voltage	For Output volt = 208V, adjustable between 220V and 240V For Output volt = 220V, adjustable between 233V and 252V For Output volt = 230V, adjustable between 244V and 264V For Output volt = 240V, adjustable between 254V and 276V For Output volt = 110V, adjustable between 117V and 127V For Output volt = 115V, adjustable between 122V and 132V For Output volt = 120V, adjustable between 127V and 138V
OPV LL: Low loss of inverter output voltage	For Output volt = 208V, adjustable between 1760V and 198V For Output volt = 220V, adjustable between 176V and 209V For Output volt = 230V, adjustable between 185V and 218V For Output volt = 240V, adjustable between 193V and 228V For Output volt = 110V, adjustable between 89V and 105V For Output volt = 115V, adjustable between 93V and 110V For Output volt = 120V, adjustable between 100V and 114V
IPV LVSD: Cut-off voltage of inverter input	Adjustable between 36V and 46V
Power Limited: Inverter output power capacity	Adjustable between 50% and 100%
Fan Speed: Fan speed level of inverter module	Selectable at 1) Normal and 2) Full
Inverter On/off: Setting all/single inverter turn on or off	<p>1. All ->On/Off 2. Single</p> <p>Serial No: xxxxxxxxxx On Off</p>

Table G–Inverter parameter settings

Parameter	Setting Option
AC HL: High loss of alternative AC input	xxxV
AC LL: Low loss of alternative AC input	xxxV
Inv HL: High loss of inverter AC input	xxxV
Inv LL: Low loss of inverter AC input	xxxV
Priority	Selectable at 1) On line and 2) Off line

Table H–STS parameter settings

6.4.1 Fan Speed Control

Output current and NTC temperature decide the fan speed. The NTC temperature has the influential priority. When the temperature is above 70°C, the fan will work in full speed. However, when the temperature is less than 60°C, the fan works according to the different load current. The fan has four levels of speed, the following tables show the relation between fan speed and load current:

Load	Detect Back	Speed	Duty
Load > 75%		Speed1	100%
75% ≥ Load > 50%	<=70%	Speed2	2/3
50% ≥ Load > 25%	<=45%	Speed3	1/3
25% ≥ Load	<=20%	Speed4	0

Table I–One fan, rotate speed1

Load	Detect Back	Speed	Duty
Load > 75%		Speed1	2/3
75% ≥ Load > 50%	<=70%	Speed2	1/3
50% ≥ Load > 25%	<=45%	Speed3	1/4
25% ≥ Load	<=20%	Speed4	0

Table J–Two fans, rotate speed2

Relation between fan speed and load current:

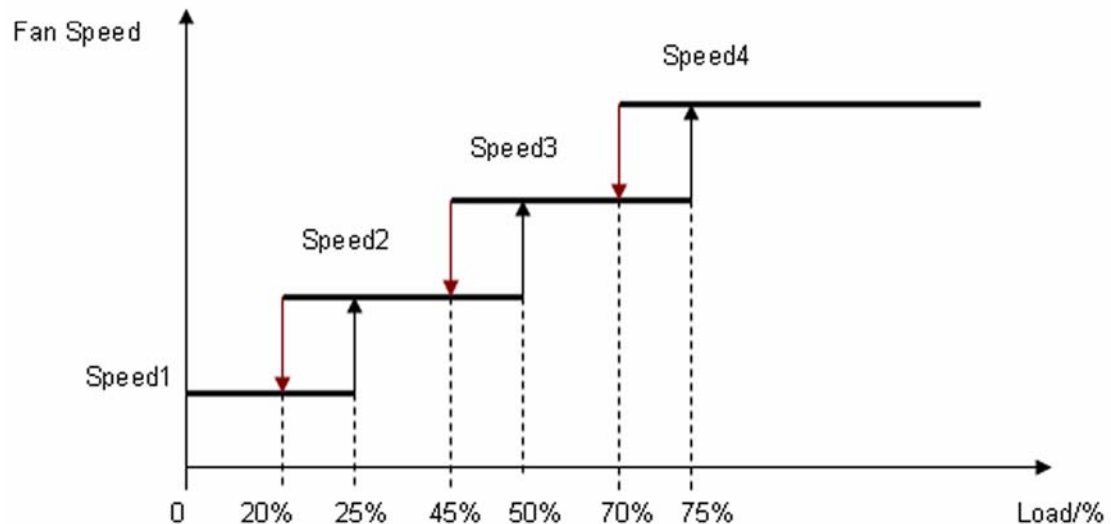



6.4.2 Alarm Settings

6.4.2.1 Clear Alarm History

In CLEAR menu, press Enter  for clearing all the alarm history.

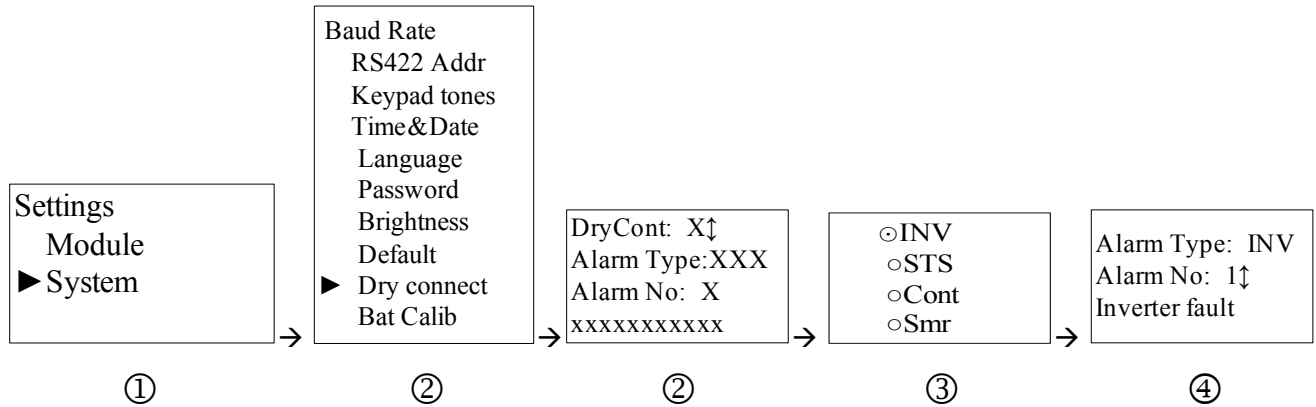

6.4.2.2 Dry Contact Alarm Configuration A



1. From the SETTING menu, select SYSTEM.
2. Then select DRY CONNECT to choose number. Use PgUp Δ key and PgDn ∇ key to change DRYCONT. Press Enter  to make selection.

```

D r y C o n t : 1 ↓
A l a r m   T y p e : I N V
A l a r m   N O : 0 2
I N v   o v e r   l o a d
  
```

3. To determine ALARM TYPE, select which module alarm group to assign to the dry contact. Press Enter  to make selection.
4. To select the alarm fault mode of the alarm type, enter ALARM NO. Press Enter  to make selection.
5. Press ESC to exit menu.

6.4.2.3 Dry Contact Alarm Configuration B

The alarm mode is programmed as follows:

No.	Static Transfer Switch	No.	Inverter
01	Inverter unavailable	01	Inverter fault
02	Main unavailable	02	Inverter over load
03	Output overload	03	Inverter fan fault
04	Output short circuit	04	Power limit
05	K1 relay open	05	DC input abnormal
06	STS SCR1 short	06	Inverter low volt off
07	STS SCR2 short		
08	Inverter bypass mode	No.	Controller
09	Over temperature	01	DC input low
10	MBS position abnormal	02	Controller temperature high
11	STS fan lock	03	Controller EPROM fault
12	STS fault mode	04	DC input over
13	STS Eeprom fault	05	CAN bus off

Table K–Dry contact alarms

7 Default Values

Setting	Default Value
STS priority	On-line
Mains high loss volt	138V
Mains low loss volt	100V
Inverter input high loss volt for STS	138V
Inverter input low loss volt for STS	100V
Inverter output high loss volt	138V
Inverter output low loss volt	100V
Inverter shutdown due to low input volt	40V
Inverter shutdown due to high input volt	60V
Inverter output volt	120V
Inverter output volt frequency	60Hz
Inverter output power limit	100%

Table L–120Vac system factory defaults

Setting	Default Value
STS priority	On-line
Mains high loss volt	264V
Mains low loss volt	185V
Inverter input high loss volt for STS	264V
Inverter input low loss volt for STS	185V
Inverter output high loss volt	264V
Inverter output low loss volt	185V
Inverter shutdown due to low input volt	40V
Inverter shutdown due to high input volt	60V
Inverter output volt	230V
Inverter output volt frequency	50Hz

Table M–230Vac system factory defaults

Setting	Default Value
RS-232, RS-422, RS-485 communication baud rate	2400bps
RS-422 address	9999
Button tone	On
LCD brightness value	45
Language	English
Password	1234
Dry contact 1	Inverter overload
Dry contact 2	Inverter unavailable
Dry contact 3	Inverter fan fault
Dry contact 4	STS fan fault
Dry contact 5	Inverter power limit

Table N–System parameter factory defaults

Alarm Type	Alarm Name	Level	Remark
Inverter	Inverter fault	Major	Inverter fault
	Inv over load	Observe	Inverter Over-loading
	Inv fan fault	Major	Inverter Fan fault
	Inv low volt off	Major	Inverter shut down due to low input voltage
	Inv Bus High	Critical	Bus voltage over the maximal level
	Inv Bus Low	Critical	Bus voltage under the minimal level
	Inv BusSoft fail	Critical	Bus Soft Start Fail
	Inv Output short	Critical	Inverter Output Short
	Inv OPV Low	Critical	Inverter output voltage low
	Inv OPV High	Critical	Inverter output voltage high
	Inv Temp High	Critical	Inverter Temperature High
	NegPow Protect	Critical	Inverter negative power protection
	SynPulse fault	Critical	Sync Pulse Fault
	Inv EPO	Critical	EPO
	SoftStart fail	Critical	Inverter soft start fail
Eeprom fail	Major	Inverter EEPROM fault	
Inv Temp High	Critical	Inverter temperature high	
STS	Inv unavailable	Major	Inverter unavailable
	Main unavailable	Major	Mains unavailable
	Output overload	Major	Output over load
	OP Short circuit	Critical	Output short circuit
	K1 Relay open	Major	Back-feed relay open
	STS SCR1 short	Critical	SCR1 short circuit
	STS SCR2 short	Critical	SCR2 short circuit
	INV Bypass Mode	Critical	Inverter bypass mode
	Over temperature	Major	STS temperature high
	MBS Abnormal	Critical	MBS in abnormal position
	STS Fan Lock	Major	STS fan fault
	STS fault mode	Critical	STS running in fault mode
	STS Eeprom Fault	Major	EEPROM fault
	SPS Power Fail	Critical	Control power fail
OutPut Abnormal	Critical	STS output normal	
Controller	Inv lost	Critical	Inverter lost
	STS lost	Critical	STS lost
	DC input low	Critical	Bat Volt Low
	Cont temp high	Critical	Controller temperature High
	Cont eeprom fail	Major	Controller EEPROM fault
	DC input Over	Critical	Bat voltage high
	CAN Bus Off	Critical	Controller CAN bus off

Table O–Alarm code factory defaults

8 Maintenance

Although very little maintenance is required with INEX systems, routine checks and adjustments by qualified service personnel are recommended to ensure optimum system performance.

The following table lists the maintenance procedures for this system. These procedures should be performed at least twice a year.

WARNING: HIGH VOLTAGE AND SHOCK HAZARD.



Use extreme care when working inside the shelf while the system is energized. Do not make contact with live components or parts.

Circuit cards, including RAM chips, can be damaged by static electricity. Always wear a grounded wrist strap when handling or installing circuit cards.

Procedure	Date Completed
Clean ventilation openings	
Inspect all system connections (re-torque as necessary)	
Verify alarm/control settings	
Verify alarm relay operation	

Table P—Sample maintenance log

8.1 Inverter Fan Replacement

1. Unlock the inverter and slide the module 10 cm (4") out of the shelf. Wait two minutes for module capacitors to discharge.
2. Remove the six (6) screws that secure the front cover to the module.
3. Gently slide the front cover (with the fans) out of the module case.
4. Disconnect the fan power connectors (one per fan).
5. Note the direction of airflow and remove the fans from the assembly.
6. Install the replacement fans following the preceding steps in reverse order.

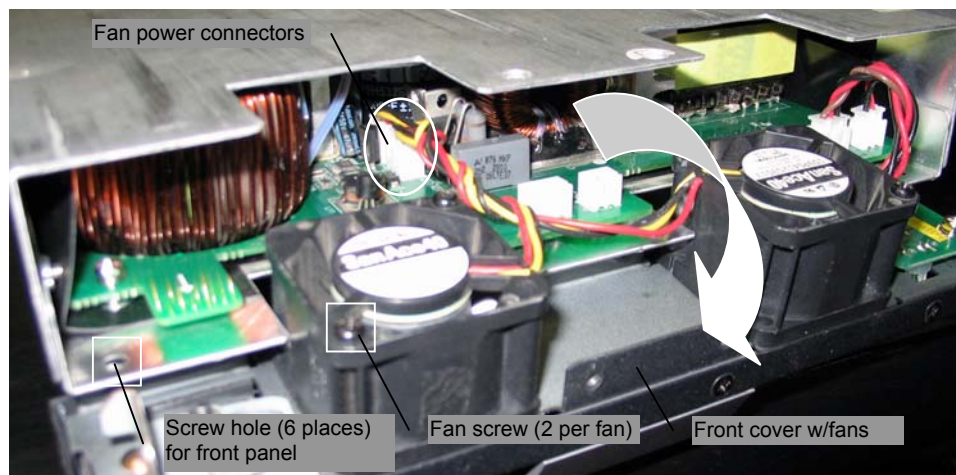

8.2 STS Fan Replacement

1. Unlock the STS and slide the module 10 cm (4") out of the shelf. Wait two minutes for module capacitors to discharge.
2. Remove the six (6) screws that secure the front cover to the module.
3. Gently slide the front cover (with the fans) out of the module case.
4. Disconnect the fan power connectors (one per fan).
5. Note the direction of airflow and remove the fans from the assembly.
6. Install the replacement fans following the preceding steps in reverse order.

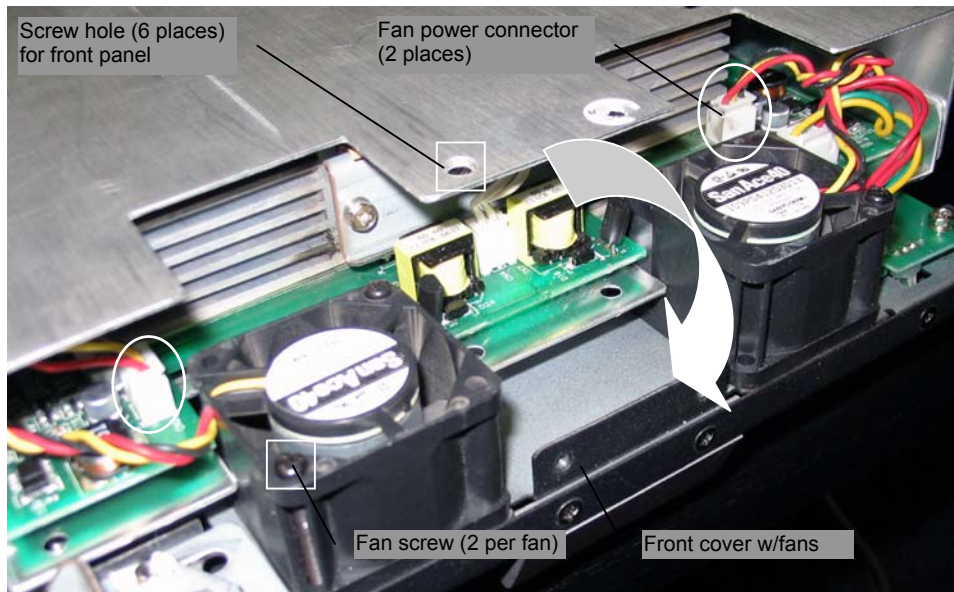

8.3 Replacement Parts

The INEX Inverter System offers a complete spare parts kit for each model number. Spare parts kits include the power modules. Parts (those included in the spare parts kit) can be ordered individually or as a complete parts kit. To order an individual part, give the full description along with the complete model and part number.

Model Number	Description	Part Number
INV-4810A	1000VA/800W inverter module (I/P: 48Vdc, O/P: 120Vac, 50/60Hz).....	014-114-10
INV-4810EA	1000VA/800W inverter module (I/P: 48Vdc, O/P: 230Vac, 50/60Hz).....	014-115-10
INV-4815A	1500VA/1200W inverter module (I/P: 48Vdc, O/P: 120Vac, 50/60Hz).....	014-116-10
INV-4815EA	1500VA/1200W inverter module (I/P: 48Vdc, O/P: 230Vac, 50/60Hz).....	014-117-10
MC-1000A	Controller module.....	018-593-10
STS-050A	50A static transfer switch module.....	019-050-10
Fan	INEX inverter/STS module fan.....	500-419-10
Cover	INEX inverter shelf rear cover.....	614-844-10
Cover	INEX STS shelf rear cover, large.....	614-845-10
Cover	INEX STS shelf rear cover, small.....	614-846-10

The above information is valid at the time of publication. Consult factory for up-to-date ordering information.

9 Troubleshooting

If the system fails to operate properly after having the installation and setup of the system thoroughly re-examined, use the following troubleshooting table to determine the probable cause(s) and solution(s) to resolve error conditions. For unlisted error conditions, please contact your local dealer for technical assistance.

Error Condition	Possible Cause	Recommendation
Inverter module cannot be properly inserted.	Improper position of nylon guide pin.	Refer to Section 3.1 to insert the nylon guide pin to correct position.
	Insertion of non-inverter module.	Check if the inserted module is not inverter module. Inverter shelf holds only inverter modules.
No AC output and all LEDs off.	Lack of input power.	Ensure input cables are all firmly connected to power source. Check if power source is not yet switched on, or is low in power.
	Mismatch of inverter modules.	Ensure inserted inverter modules have the same specifications.
No AC output. Both green and yellow LEDs flicker.	Inverter self-diagnosis.	Inverter self-diagnosis takes a few seconds. LED turns to a solid green light after the completion of self-diagnosis.
No AC output. Both yellow and red LEDs are on.	Load exceeds 125%.	Ensure the load is no higher than 100% of the total power rating. Reduce as required.
No AC output. Red LED is on.	1. Input wiring is connected in reverse (i.e. reverse polarity).	Ensure input cables are connected to correct polarity (positive to positive, negative to negative).
	2. Output voltage is out of operating range.	Adjust voltage to ensure that the connected device is within the inverter output voltage range.
	3. Inverter output is shorted.	Turn off the input power source to remove all short circuits.
	4. Negative Power Protection.	For multi-shelf system , any jumper insertion on JP2 connector would obstruct parallel connections. Remove jumper from JP2 connector. For single-shelf system , jumper on JP2 connector pools two inverter modules. Ensure there is a jumper on JP2 connector.
Red LED blinks fast.	1. Inverter fails to soft start.	Reboot the inverter system by switching off and on the input power source.
	2. Inverter temperature rises beyond the temperature limit.	Leave inverter idle to cool down for few minutes.
AC output exists with yellow LED flickering.	Input voltage is out of operating range.	Ensure input voltage is between 45 to 58Vdc.
AC output exists and yellow LED is on.	Load is over 100% but below 125%.	Ensure the load is no higher than 100% of the total power rating. Reduce as required.
Inverter continuously delivers power, but with red LED flickering slowly.	Failure of EEPROM.	Reboot the inverter system by switching off and on the input power source.
	Fans failure.	Check if the fans are locked or fail to work. If fan is locked, remove the obstruction; if fan fails to work, replace the fan.





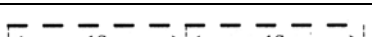



Table Q–Troubleshooting for inverter module

Inverter Module LED Display Status			
Priority	Green LED	LED Signal	Status
↓ Low High ↓	Solid		Inverter work normally
	Blink (slow)		Inverter is being inquired
	Blink (intermittent (slow))		One of the status as follows: 1) Power On. Details refer to note. 2) Shut down remotely.
Priority	Yellow LED	LED Signal	Status
↓ Low High ↓	Blink (intermittent (slow))		Power On Details refer to note.
	Solid		Over Load (Load percent > 100%)
	Blink (fast)		DC input abnormal (Vin<=45V or Vin>=58V)
	Blink (intermittent (fast))		Inverter shut down due to super low/super high input (Vin<=VLVSD or Vin>=VHVSD)
Priority	Red LED	LED Signal	Status
↓ Low High ↓	Blink (slow)		One of the alarms as follows: 1) EEPROM Fault. The inverter cannot work in parallel mode system, however, it can work in single mode system. 2) Inverter Fan Fault. Fan fails in operation.
	Blink (fast)		One of the alarms as follows: 1) Internal DC Bus Over/Under/Unbalance/soft start fail. The inverter will shut down. It cannot restart automatically. 2) Temperature High. The inverter will shut down. It cannot restart automatically.
	Solid		One of the alarms as follows: 1) Input reverse polarity. The DC input voltage polarity is reverse. 2) Inverter output Short circuit. When short circuit happens, inverter will shut down. Manual restart is required. 3) Abnormal output voltage. The inverter will shut down when output voltage is out of operating voltage range. It cannot restart automatically. 4) Negative Power Protection. The inverter will shut down. It cannot restart automatically. 5) Overload fault. When the time of overload protection exceeds the defined time, the inverter will shut down. Then inverter should be manually restarted.

Table R–Inverter LED indicator display

Error Condition	Possible Cause	Recommendation
No AC output and all LEDs off.	Lack of input power	Ensure input cables and bus bars are all firmly connected to power source. Check if inverter output or mains AC are not yet switched on, or are low in power.
Priority is On line, STS AC output is normal but with yellow LED on	STS AC input source is from inverter. The inverter is in normal status, but the utility line is in abnormal status.	Check AC mains connection and status.
Priority is On line, STS AC output is normal but with green LED flash 1 time/s	STS AC input source is from utility, the inverter is in normal status. Maybe the current load is out of capability of inverter, or the inverter is just from abnormal status back to normal.	Please refer to inverter troubleshooting guide.
Priority is On line, STS AC output is normal but with green LED flash 1 time/s, and yellow LED on	STS AC input source is from utility, and inverter is in abnormal status.	Please refer to inverter troubleshooting guide.
No AC output, yellow LED is on	Both inverter and utility AC source are in abnormal status.	Check AC mains and inverter output.
Priority is off line, AC is normal from Mains, but yellow LED is on	STS AC input source is from utility, and inverter is in abnormal status.	Please refer to inverter troubleshooting guide.
Priority is off line, AC is normal, but green LED flash 1 time/s	STS AC input source is from inverter, utility is just from abnormal status back to normal.	Check AC mains connection and status.
No AC output, yellow LED flash 2 times/s	The relay of utility power side is broken and cannot form close circuit.	Turn MBS to mains or inverter bypass mode, maintain the STS module
AC output is normal, green LED is on or flash 1 time / second, yellow LED flash 2 times/s	The relay of utility power side is broken and cannot form close circuit.	Turn MBS to mains or inverter bypass mode, maintain the STS module.
AC output is normal, green LED is on, red LED flash 1 time/s	Fan fails	Turn MBS to mains or inverter bypass mode, maintain the STS fan.
AC output is normal, green LED is on, red LED flash 1 time/s	EEPROM FAULT EEPROM can't write or read data correctly.	This will not influence the STS AC output. The alert will be off automatically after 10s.
AC output is normal, green LED is on, red LED flash 1 time/s	CAN communication error	Check the connection of CAN signal cables.
AC output is normal, green LED is on, red LED flash 2 times/s	SCR short fault	Turn MBS to mains or inverter bypass mode, maintain the STS.
AC output is normal, green LED is on, red LED flash 2 times/s	Auxiliary Power Supply fault	Turn MBS to mains or inverter bypass mode, maintain the STS.
AC output is normal, green LED is on, red LED flash 5 time/s	MBS provides 3 sets of signals to STS for detecting MBS position. When the connection is off or not at valid position, this alert appears.	Ensure the MBS and STS signal cables are connected.
AC output is off, red LED on, other LEDs off	STS fault mode	Turn MBS to mains or inverter bypass mode, maintain the STS.
AC output is off, red LED on, other LEDs off	Over temperature	Turn MBS to mains or inverter bypass mode, maintain the STS. Check if the environmental temperature is higher or if there is anything blocking the vent.
AC output is off, red LED on, other LEDs off	Over load	Decrease or remove the loads, then shut down or remove the STS module. Then reconnect and restart.
AC output is off, red LED on, other LEDs off	Output short	Decrease or remove the loads, then shut down or remove the STS module. Then reconnect and restart.
AC output is normal, green and yellow LEDs flash 2 times/s	Inverter bypass mode	STS internal temperature is too high. Check if anything is blocking the vent or if module has been working overload for a long time.

Table S–Troubleshooting for STS module

Inverter Module LED Display Status			
Priority	Green LED	LED Signal	Status
Low ↓ High	Solid		STS work Normally
	Blink (slow)		Running mode not accord with setting priority, for example, STS work in off-line mode, but the priority is on-line
	Blink (fast)		STS work in Inverter bypass mode (the internal mode of STS, not mean IBP of MBS)
Priority	Yellow LED	LED Signal	Status
Low ↓ High	Solid		Mains or Inverter abnormal
	Blink (fast)		If the status of green LED is the same as yellow LED, then it stands for Inverter bypass mode, otherwise it means Back-feed relay open
	Blink (fastest)		STS Output abnormal
Priority	Red LED	LED Signal	Status
Low ↓ High	Blink (slow)		Fan lock or CAN communication fail or EEPROM fault
	Blink (fast)		SCR short or auxiliary power supply fault
	Blink (fastest)		MBS position abnormal
	Solid		STS Fault mode, maybe overload or over temperature or output short

NOTE: If more than one warning exists at the same time, then the LED will display the highest priority.

Table T–STS LED indicator display

Alarm Priority	LED Indicator Status
Observe	Green: On Yellow: On Red: off.
Major	Green: On Yellow: off Red: On
Critical	Green: On Yellow: off Red: On Buzzer chirp

Table U–Operating sequence troubleshooting table

10 Argus Conventions

10.1 Numbering System

Argus Technologies uses an eight-digit drawing number system, which is broken into three blocks. The first three digits describe the category of the product; e.g., rectifier or fuse panel. The next three digits indicate the sequence in which the product number was allocated in a particular category. The last two digits indicate the type of drawing, for example:

“-05”	Schematic
“-08”	Customer Connections
“-20”	Main Assembly

Argus uses an eight-digit part numbering system for all components and sub assemblies. Each part is covered by its own unique number. Due to the quantity, categories will not be listed within this manual.

10.2 Acronyms and Definitions

AC	Alternating current
ANSI	American National Standards Institute
AWG	American Wire Gauge
BTU	British thermal unit
CAN	Controller area network
CEC	Canadian Electrical Code
CSA	Canadian Standards Association
DC	Direct current
EIA	Electronic Industries Alliance
EMC	Electromagnetic compatibility
EMI	Electromagnetic interference
ERM	<u>E</u> lectromagnetic <u>C</u> ompatibilty and <u>R</u> adio <u>S</u> pectrum <u>M</u> atters
ESD	<u>E</u> lectrostatic <u>D</u> ischarge
FCC	Federal Communications Commission (for the USA)
HVSD	<u>H</u> igh <u>v</u> oltage <u>s</u> hutdown
IEC	International Electrotechnical Commission
IEEE	Institute of Electrical and Electronics Engineers
LED	Light emitting diode
LVD	Low voltage disconnect
MTBF	Mean time between failures
NC	Normally closed
NEC	National Electrical Code (for the USA)
NO	Normally open
OSHA	Occupational Safety & Health Administration
OVP	Over voltage protection
RAM	Random access memory
RU	Rack unit (1.75”)
THD	Total harmonic distortion
UL	Underwriters Laboratories

11 Outline Drawings

11.1 Mechanical Dimensions of INEX Inverter Module

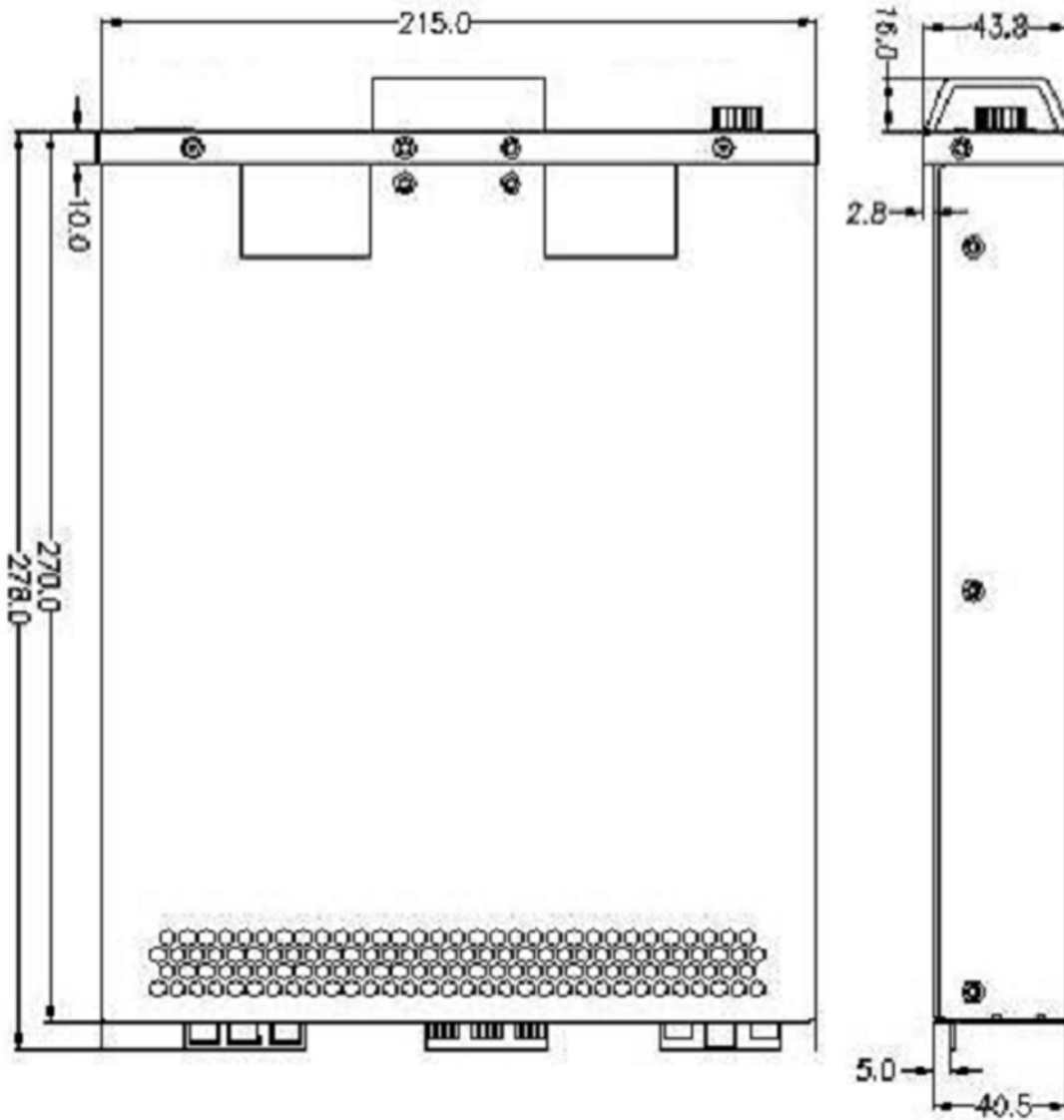
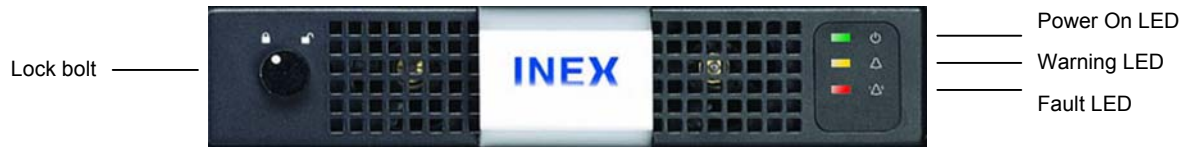

11.2 Mechanical Dimensions of INEX STS Module

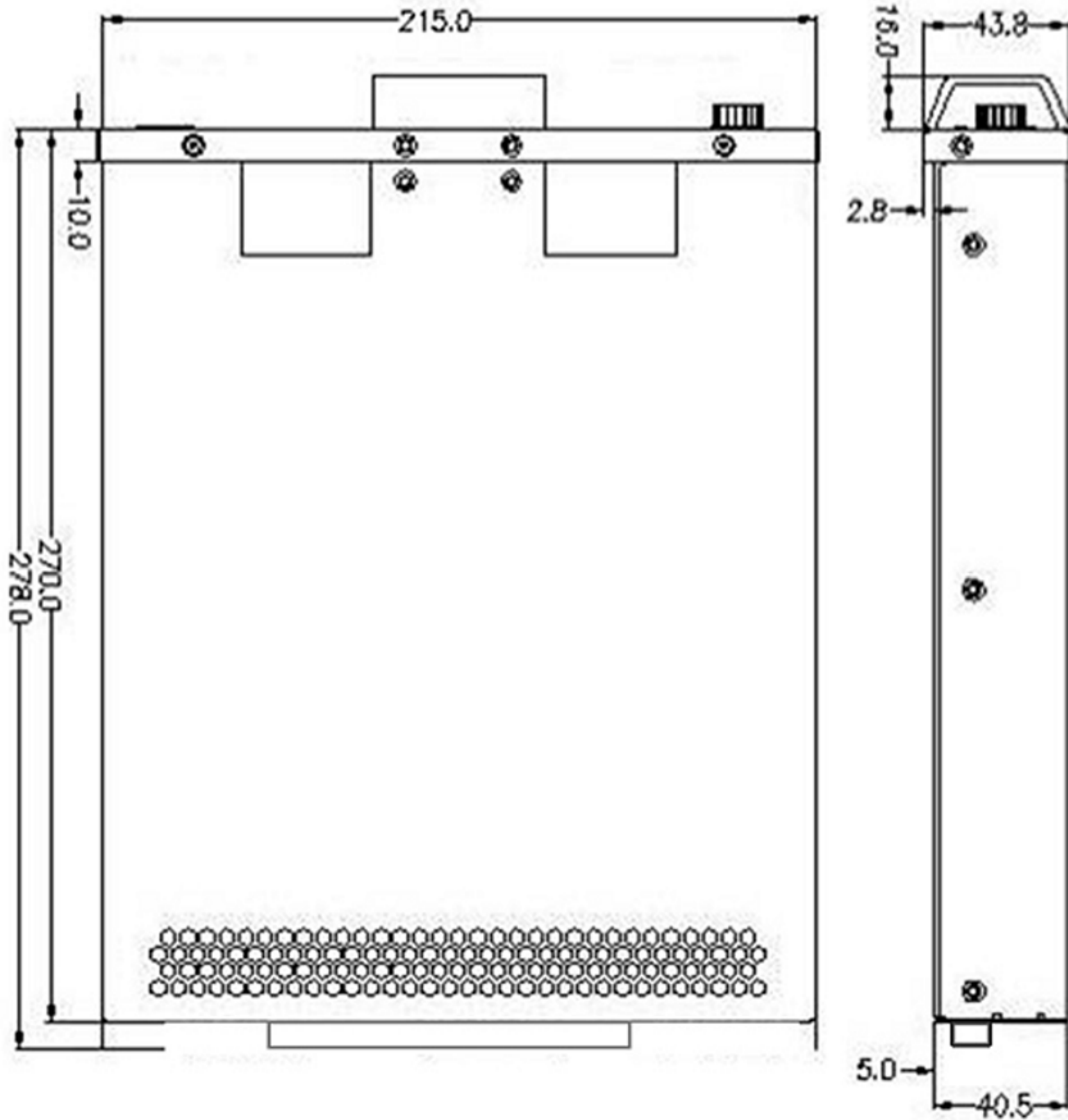
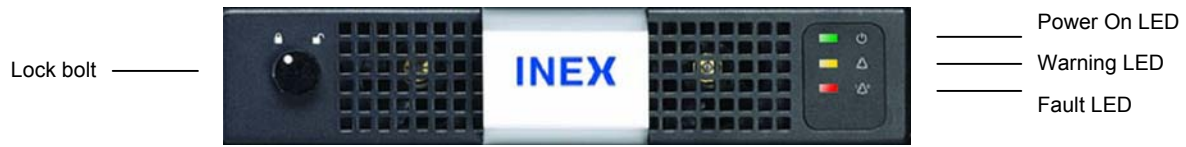

11.3 Mechanical Dimensions of INEX Controller Module

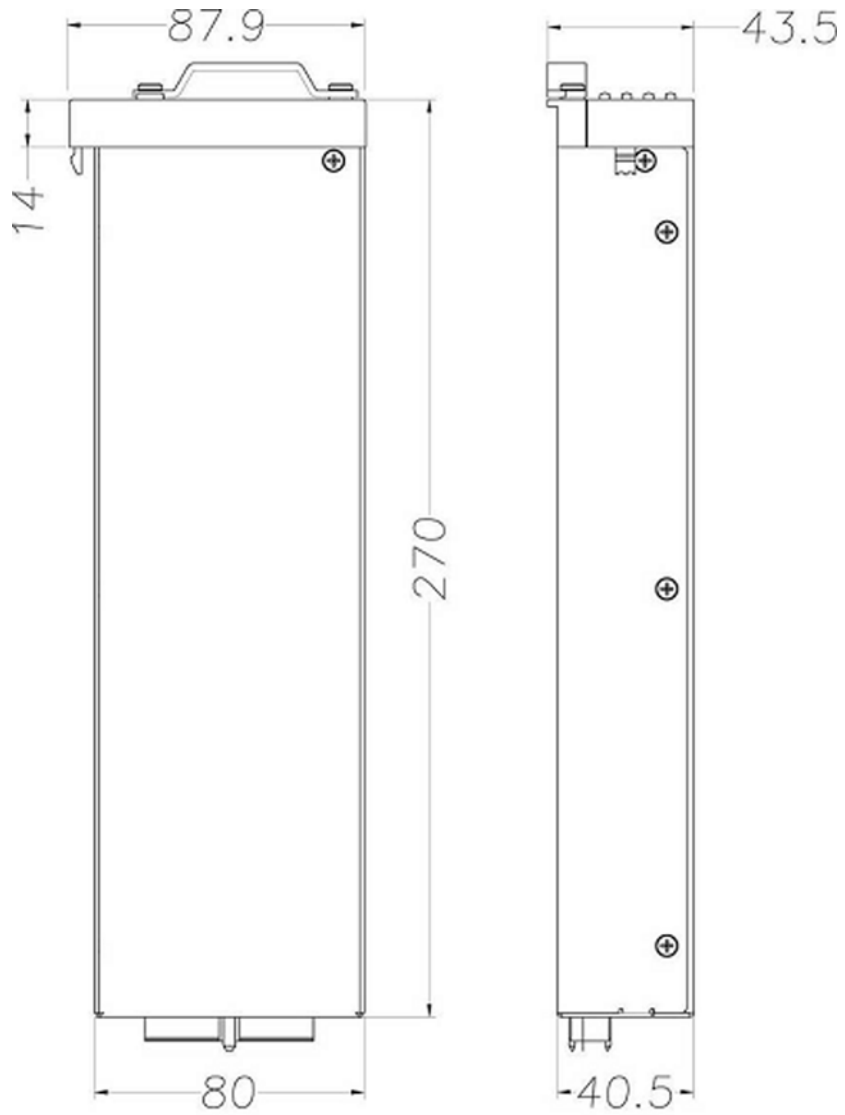

11.4 Mechanical Dimensions of INEX Interface Module

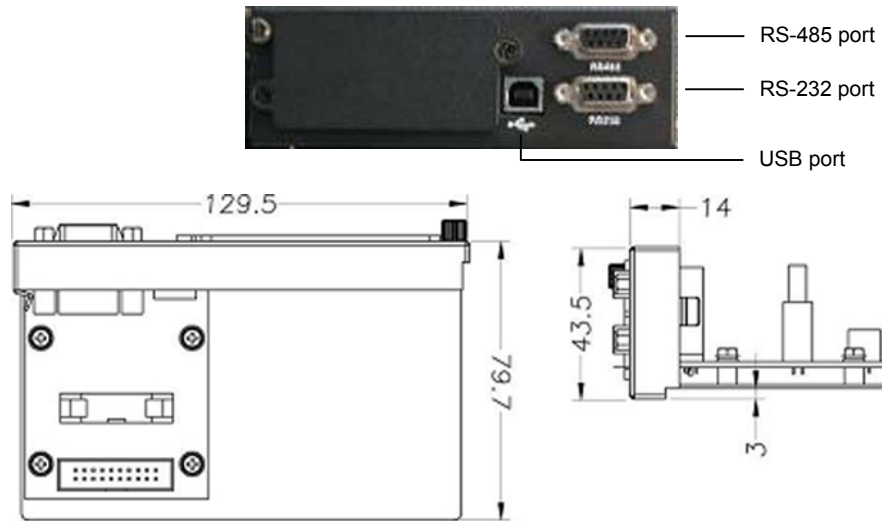

11.5 Mechanical Dimensions of INEX Inverter Shelf

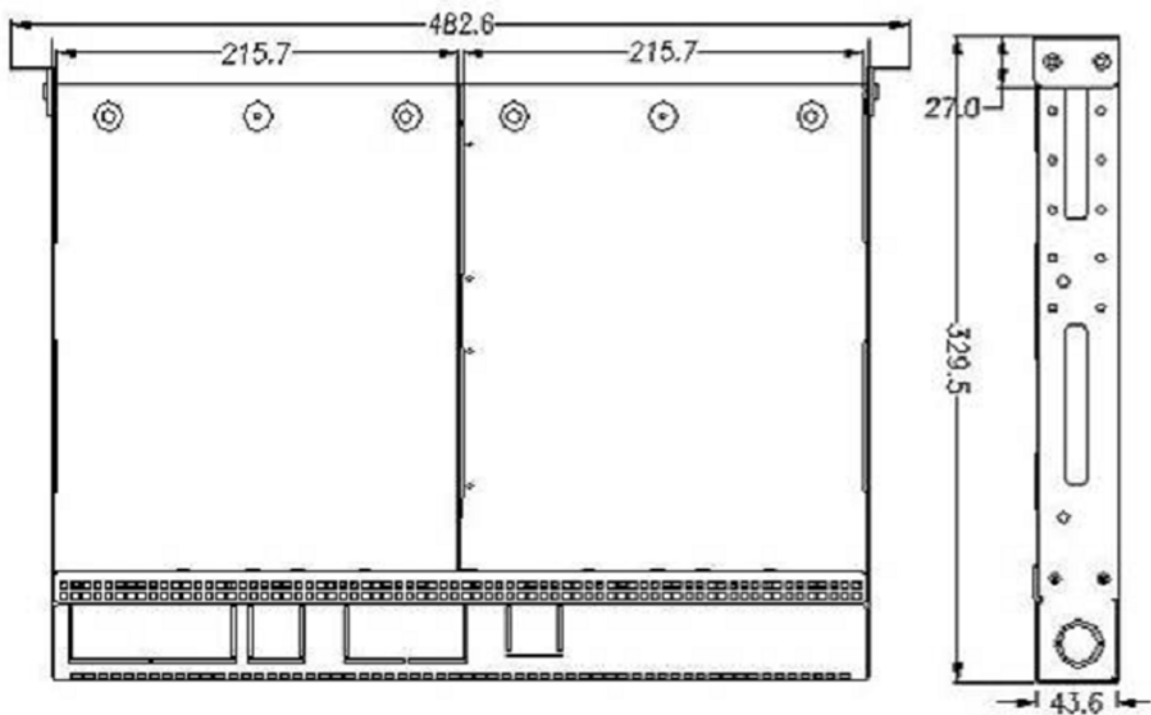
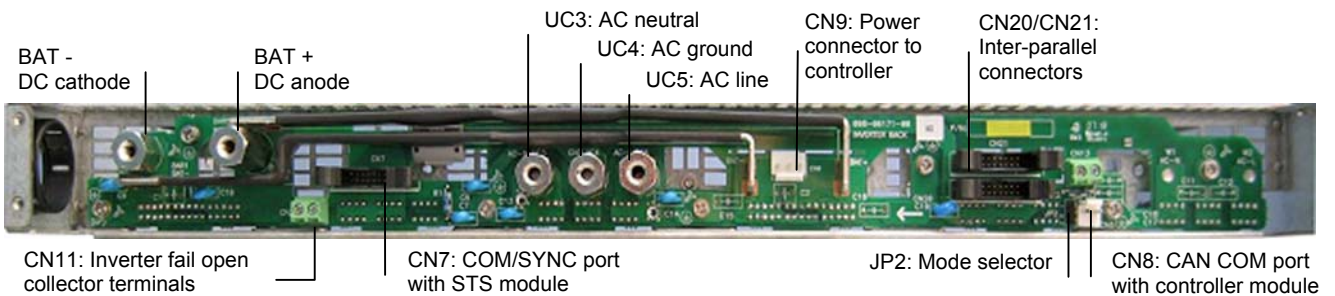

11.6 Mechanical Dimensions of INEX Controller/Interface/STS Shelf

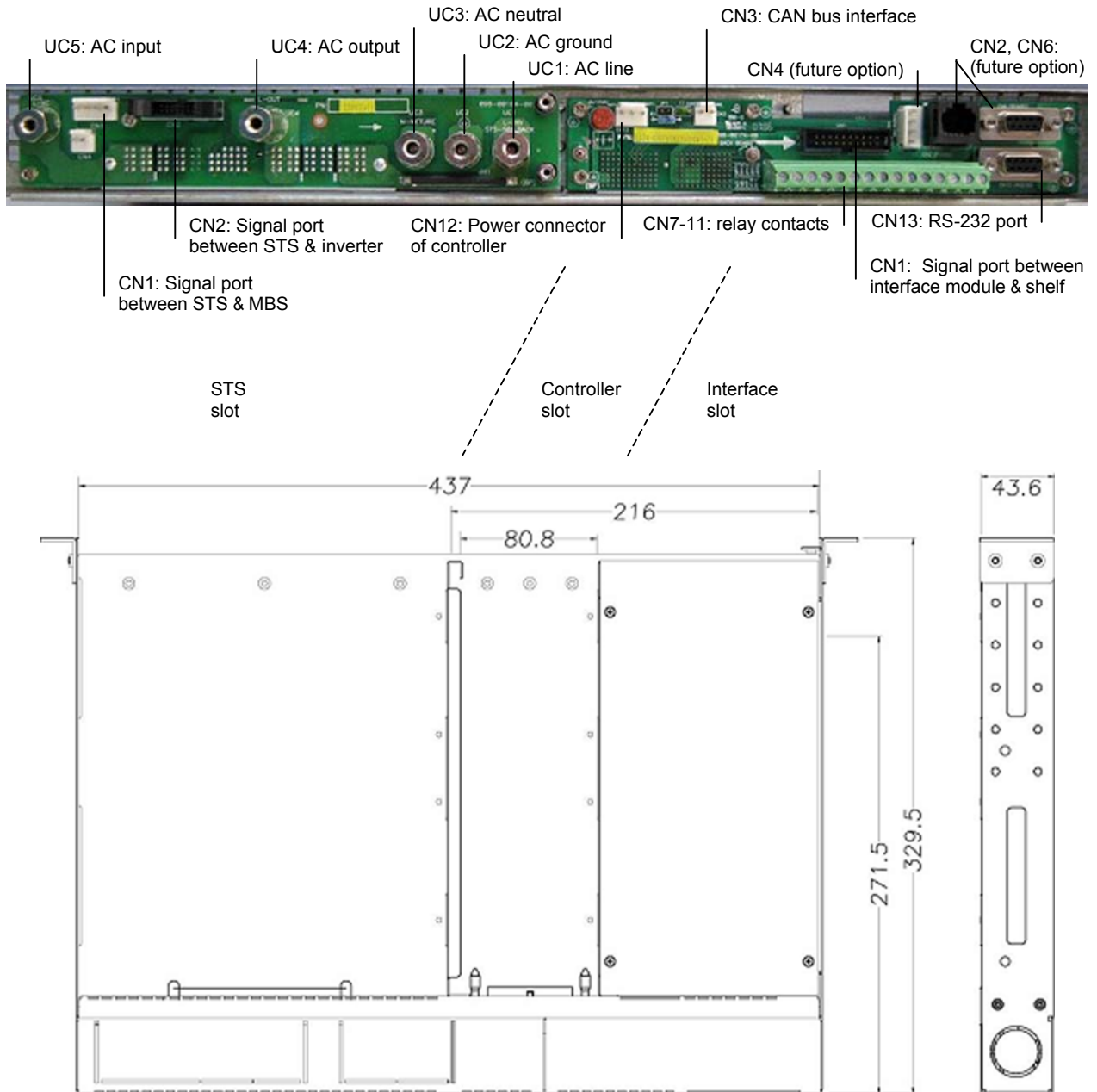

11.7 Mechanical Dimensions of INEX MBSDU Shelf

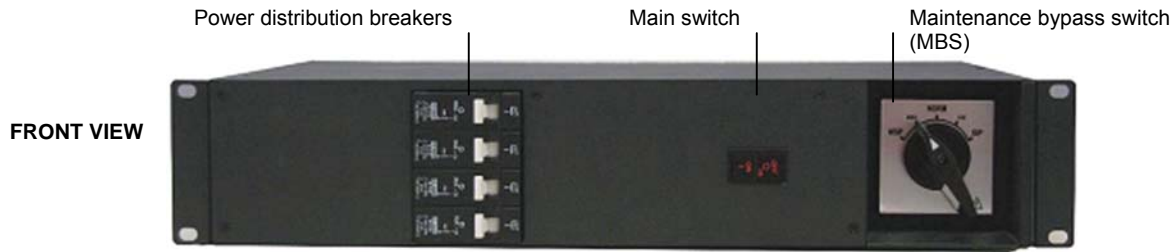
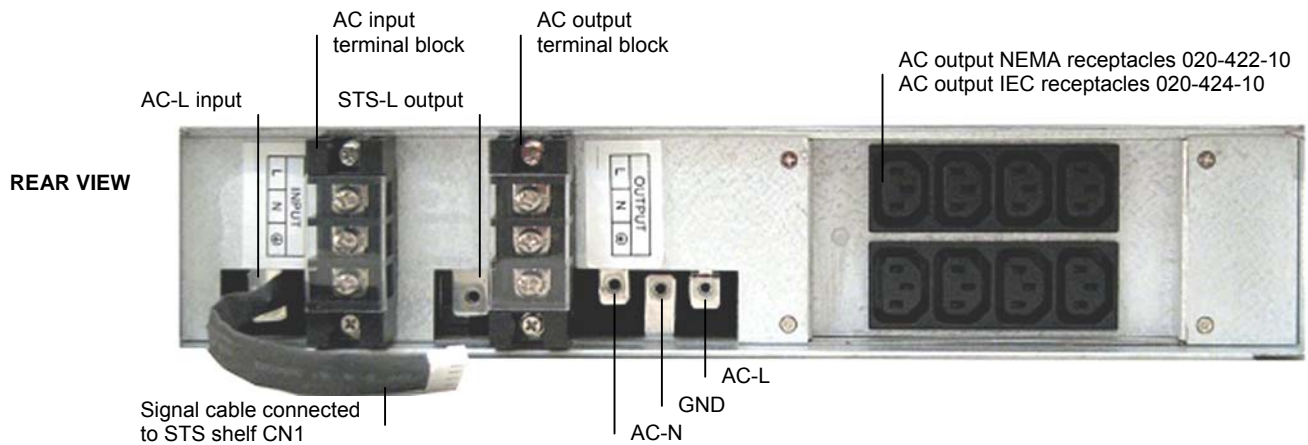
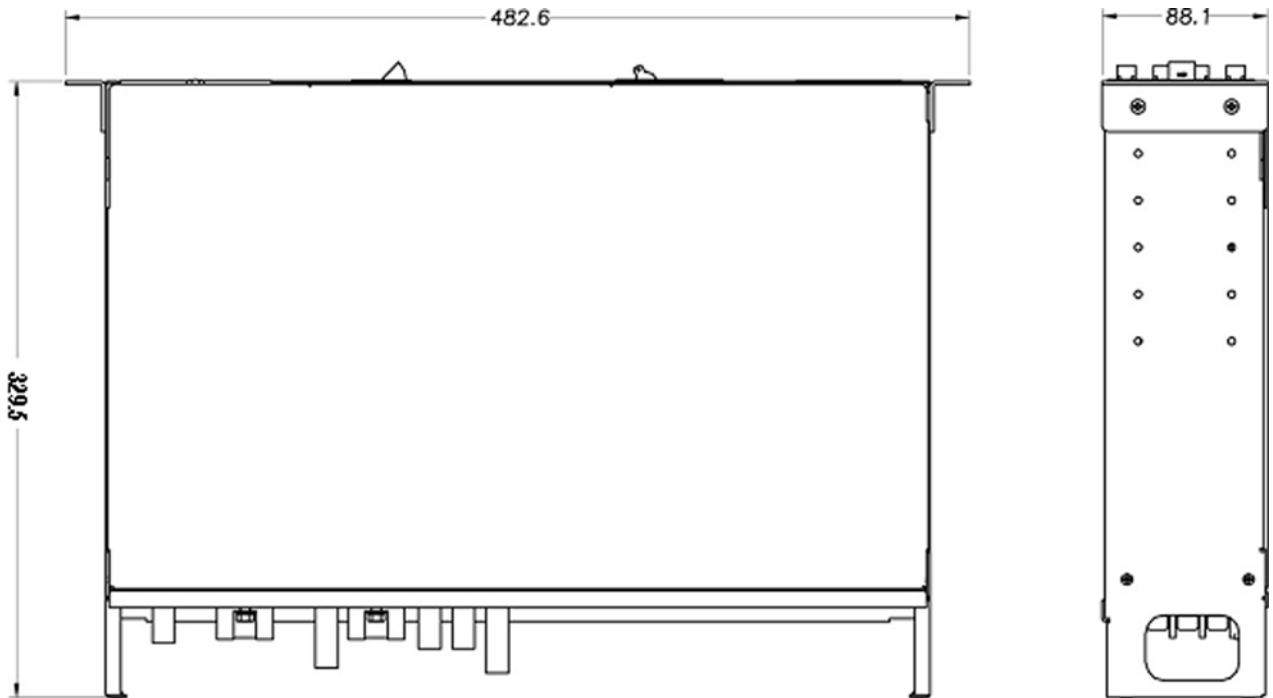

Illustration only and may not match your model.



FACTORY SERVICE INFORMATION

Technical Support

Technical support staff are available for answering general questions related to installation, operation and maintenance of Argus products. In Canada and the USA, call Argus toll free 7:30 am to 5:00 pm Pacific Standard Time at:

+1-888 GO ARGUS

(+1-888-462-7487)

For emergencies, call +1-888-GO-ARGUS 24 hours a day, seven days a week.
Customers outside Canada and the USA, call +1-604-436-5547 for technical support.

Training

Argus offers various levels of product and technical training. These workshops provide a mix of theory and hands on application for qualified customers. Please consult your sales representative for course schedules, locations and costs, or visit our website at www.argusdcpower.com.

Factory Repair and Servicing

All service, beyond initial adjustments, should be carried out by qualified factory service personnel. For these procedures, please contact Argus Technologies at the locations listed to the right.

Product Returns

Before returning any product for service, please obtain a Return Material Authorization (RMA) number from an Argus factory service representative. The representative will require the model and serial number, as well as a brief description of the problem prior to issuing the RMA number. All material must be pre-authorized before being returned.

See document 048-507-10 "Warranty and Repair Information" for more details.

Moving and Storage

Units must be suitably packed in the original shipping container (or equivalent) prior to re-shipping. The box should be completely enclosed and constructed of wood or double-wall, corrugated cardboard. At least 3" of foam or shock absorbing packing material must surround the unit.

Factory Service Centers

Canada and International

Argus Technologies Ltd.
ATTN: RMA Returns
7033 Antrim Avenue
Burnaby, BC, V5J 4M5 Canada
Tel: +1 604 436 5900
Fax: +1 604 436 1233
Email: returns@argusdcpower.com

USA

Argus Technologies Inc.
ATTN: RMA Returns
3116 Mercer Avenue
Bellingham, WA, 98225 USA
Tel: +1-360 756 4904
Fax: +1-360 647 0498
Email: returns-usa@argusdcpower.com

Asia-Pacific

PCM Electronics (Dong Guan) Co., Ltd.
Hongli Industrial Area, Miaobian, Liaobu Town,
Dongguan City, Guangdong Province,
523400 China
Tel: +86 755 8895 3310
Fax: +86 755 8895 3307

Authorized Service Center

Argentina

Argus Technologies de Argentina
Belen 315, Capital Federal, Buenos Aires,
14071 Argentina
Tel: +54 (11) 4672 4821
Fax: +54 (11) 4504 4698
Cell: +54 9 (11) 4993 9996
Email: ikleiman@argus.ca

Asia

Argus Technologies Asia Pte Ltd
Blk 6 Tagore Lane #160
Singapore 787570
Tel: +65 6458 8900
Fax: +65 6458 2122

Australia

CPS National
8/376 Newbridge Rd
Moorebank, NSW, 2170 Australia
Tel: +61 02 9822 8977
Fax: +61 02 9822 8077

Australia/New Zealand

Alpha Power Systems Pty Ltd
Unit 3, 30 Heathcote Road
Moorebank, NSW, 2170 Australia
Tel: +61 02 9602 8331
Fax: +61 02 9602 9180

Century Yuasa

37 - 65 Colbalt Street
Carole Park QLD 4300
Australian Sales & Service
Tel: +61 07 3361 6587
Fax: +61 07 3361 6705
New Zealand Sales & Service
Tel: +64 9 978 6689
Fax: +64 9 978 6677

Canada

Compower Systems Inc.
118 Tiffield Road
Toronto, ON, M1V 5N2 Canada
Tel: +1 416 293 3088
Fax: +1 416 293 0671

Europe

Alpha Technologies Europe Ltd.
Cartel Business Estate
Edinburgh Way
Harlow, Essex, CM20 2DU UK
Tel: +44 1279 422110
Fax: +44 1279 423355

Mexico & Central America

Technologies Argus First De Mexico SA de CV
Anatole France No. 17
Col. Polanco
Mexico City, 11560 Mexico
Tel: +52 55 5280 6990
Fax: +52 55 5280 6585

South America

Argus Technologies Argentina
Santo Tome 2573, Capital Federal
Buenos Aires, 1416 Argentina
Tel: +54 11 4504 4698
Cell: +54 9 11 4993 9996
E-pager: 541149939996@nextel.net.ar

Turkey

IPC Enerji Elk San ve TIC AS
Inonu cad. Kanarya sok. No:20
Yenisahra - Kadikoy
Istanbul, Turkey
Tel: +90 216 317 41 42
Fax: +90 216 472 90 66