

ARGUS[®]

INV2000 Standalone Inverter User Manual

014-129-B2



Visit us at www.argus.ca

Power

This page intentionally left blank.

INV2000 Standalone Inverter User Manual

014-129-B2

Applies to inverter modules 014-129-10 and 014-130-10.

The following documents and drawings are included in this manual to provide the necessary information required for installation, operation and fault diagnosis of the unit:

- **Specifications:** 014-129-B1
- **Installation and Operation Instructions:** 014-129-C0
- **Service Centers:** 048-693-10

Specifications for INV2000 Standalone Inverter

DC Input

Nominal Voltage:	48Vdc
Operating Range:	40 to 60Vdc within rated limits
Under Voltage Warning Threshold:	45Vdc
Under Voltage Threshold:	40Vdc
Over Voltage Warning Threshold:	58Vdc
Over Voltage Threshold:	60Vdc
Inrush current:	<2 x Irated
Isolation DC-enclosure:	707Vdc (varistors and filter capacitor removed)/1min
Input Protection:	Reverse polarity protection
Psophometric Noise Voltage:	≤1.0mV ITU-T O.41 (16.66 to 6000Hz)
Wide Band Noise:	<1.0mV (psophometric, 25Hz to 5kHz) <20mVrms (25Hz to 20kHz)
Peak to Peak Noise:	<150mV up to 100MHz

AC Input (with transfer switch)

Voltage Range:	110/115/120Vac: 89 to 138Vac 208/220/230/240Vac: 176 to 276Vac
Over Voltage Threshold:	276 / 138Vac
Under Voltage Threshold:	176 / 89Vac
Frequency Range:	50/60 ±2.5% Hz
Back-feed Protection:	Comply with safety requirement
Transfer Time:	8ms when Inverter → Mains AC 10ms when Mains AC → Inverter

AC Output

Power Capacity:	2000VA/2000W
Waveform:	Pure sine wave
Power Factor:	1.0
Nominal Output Voltage:	110/115/120Vac or 208/220/230/240Vac
Voltage Regulation:	±2%
Output Frequency:	50/60Hz
Frequency Variation:	±0.5%
Frequency Setting:	Manually, field-selectable

Specifications for INV2000 Standalone Inverter Continued

Crest Factor:	3:1
T.H.D. (Current):	<3% for linear load, <5% for non-linear load
Capacitive/Inductive Load:	-1.0 to +1.0 without exceeding permissible distortion for resistive load
Efficiency:	>91%
Current Limitation:	Electronic current limitation at overloads and short circuits
Isolation AC-enclosure:	Basic isolation (Pri-Gnd) 2121Vdc/1min
Isolation AC-DC:	Reinforced isolation (Pri-Sec) 4242Vdc/1min
Surge Protection:	EN61000-4-5, Telcordia GR-1089 CORE, ANSI/IEEE C62.41, STD 587-1980
Dynamic Response:	Better than $\pm 10\%$ according to IEC 62040-3 Class 1
Over Load Protection:	1.2 x Inom permanent overload capacity @30°C (86°F) 1.5 x Inom >10s 2 x Inom >5s

Mechanical

Dimensions:	43.8mm H x 440mm W x 360mm D [1.73" H x 17.3" W x 14.2" D]
Weight:	7.4 kg (16.3 lb.) for 230Vac model 7.6 kg (16.8 lb.) for 120Vac model

Environmental

Operating Temperature:	-20 to +60°C (-4 to +140°F) -20 to +50°C (-4 to +122°F) with full performance
Storage Temperature:	-30 to +80°C (-22 to +176°F)
Operating Humidity:	0 to 95% relative, non-condensing
Heat Dissipation:	Forced air cooling
Operating Altitude:	1500m (4922 feet)
Audible Noise:	55dB ETS 300 753 Class 3.1

Standards

Safety Compliance:	Comply with EN 60950-1/UL 60950-1
Certification:	CE
RoHS:	Compliant
EMC:	EN300 386:2001 Class B compliance
MTBF:	$\geq 200,000$ hours as per Telcordia SR-332

The above information is valid at the time of publication. Consult factory for up-to-date ordering information. Specifications are subject to change without notice.

IMPORTANT SAFETY INSTRUCTIONS

SAVE THESE INSTRUCTIONS

This section contains important instructions that should be followed during the installation and maintenance of equipment and batteries. **Please read all of the instructions before operating the equipment, and save this manual for future reference.**

The following safety symbols will be found throughout this manual, carefully read all information and abide by the instructions:



DANGEROUS VOLTAGE
This symbol indicates a dangerous voltage exists in this area of the product.



GAS HAZARD
This symbol indicates a gas hazard exists in the area of vented batteries.



NO MATCHES OR OPEN FLAMES
This symbol indicates a fire or explosive hazard exists in the area of the product.

The following levels of warning will be used with the above symbols:

- DANGER:** You WILL be KILLED or SERIOUSLY INJURED if instructions are not followed closely.
- WARNING:** You CAN be KILLED or SERIOUSLY INJURED if instructions are not followed closely.
- CAUTION:** You CAN be INJURED or equipment can be DAMAGED if instructions are not followed closely.

Before using the product, read all instructions and cautionary markings on the product and any equipment connected to the product.

This unit is designed for indoor use only. Do not expose the product to rain or snow; install only in a clean, dry environment.

CAUTION – To reduce the risk of fire hazard, do not cover or obstruct the ventilation openings. Do not install the inverter in a zero-clearance compartment.

CAUTION – Unless otherwise noted, use of an attachment not recommended or sold by the product manufacturer may result in a risk of fire, electric shock, or injury to persons.

CAUTION – Do not operate the product if it has received a sharp blow, it has been dropped, or otherwise damaged in any way – return it to a qualified service center for repair.

CAUTION – Do not disassemble the product – call our qualified service centers for servicing. Incorrect reassembling may result in a risk of electrical shock or fire.

WARNING – The input and output voltages of the product are hazardous. Extreme caution should be maintained when servicing or touching conductive components connected to the product.

Mechanical Safety

Power equipment can reach extreme temperatures under load.

Use caution around sheet metal components and sharp edges.

Electrical Safety

WARNING



To avoid a risk of fire and electric shock, make sure that existing wiring is in good condition and that wire is not undersized. Do not operate the inverter with damaged or substandard wiring.

Before working with any live battery or power system, follow these precautions:

- Remove all metallic jewelry; e.g., watches, rings, metal rimmed glasses, necklaces.
- Wear safety glasses with side shields (and prescription lenses if necessary) at all times during installation.
- Use OSHA approved insulated hand tools.

Do not work alone under hazardous conditions.

Ensure no liquids or wet clothes contact internal components.

Battery Safety

Servicing and connection of batteries shall be performed by, or under the direct supervision of, personnel knowledgeable of batteries and the required safety precautions.

Never reverse DC+ and DC- to battery.

Keeps the battery away from heat sources including direct sunlight, open fires, microwave ovens and high-voltage container. Temperatures over 60°C may cause damage. Make sure the area around the battery is well ventilated.

Always wear eye protection, rubber gloves, and a protective vest when working near batteries. Remove all metallic objects from hands and neck.

Use OSHA approved insulated hand tools. Do not rest tools on top of batteries.

Have plenty of fresh water and soap nearby in case battery acid contacts skin, clothing, or eyes.

Batteries contain or emit chemicals known to the State of California to cause cancer and birth defects or other reproductive harm. Battery post terminals and related accessories contain lead and lead compounds; wash hands after handling (California Proposition 65).

If battery acid contacts skin or clothing, wash immediately with soap and water. If acid enters your eye, immediately flood it with running cold water for at least twenty minutes and get medical attention immediately.

If you need to remove a battery, always remove the grounded terminal from the battery first. Make sure all accessories are off so you don't cause a spark.



WARNING

Follow battery manufacturer's safety recommendations when working around battery systems.



WARNING

Do not smoke or present an open flame when batteries (especially vented batteries) are on charge. Batteries vent hydrogen gas when on charge, which creates an explosion hazard.

Batteries are hazardous to the environment and should be disposed of safely at a recycling facility. Consult the battery manufacturer for recommended local authorized recyclers.

Wiring Requirements

Inverter is intended to be installed as part of a permanently grounded electrical per the National Electric Code ANSI/NFPA 70 (current edition). This is the single point earth ground for the unit.

The ground on the Inverter is marked with this symbol: G /

The AC voltage and current on the Inverter is marked with this symbol: L / N

The DC voltage and current on the Inverter is marked with this symbol: - - - -

TABLE OF CONTENTS

SECTION	PAGE
1 INTRODUCTION	1
1.1 Scope of the Manual	1
1.2 Product Overview	1
2 INSPECTION	2
2.1 Packing Materials	2
2.2 Check for Damage	2
3 INSTALLATION AND WIRING	3
3.1 Where to Install	3
3.2 Unit Installation.....	3
3.3 Unit Removal.....	3
3.4 AC Safety Grounding	3
3.5 DC Wiring Connections.....	4
4 OPERATION	5
4.1 Front Panel.....	5
4.2 Rear Panel	8
4.3 Pre-Operation Check	10
4.4 Status Monitoring	10
4.5 Parameter Settings	11
4.6 Alarm Settings.....	13
4.7 Remote ON/OFF Switch	13
4.8 Turning On The Load	13
5 MAINTENANCE AND TROUBLESHOOTING	14
5.1 Preventative Maintenance	14
5.2 Troubleshooting Guide.....	14
6 DEFAULT VALUES	15
7 ARGUS CONVENTIONS	16
7.1 Numbering System.....	16
7.2 Acronyms and Definitions	16
8 OUTLINE DRAWINGS	17

1 Introduction

1.1 Scope of the Manual

This instruction manual explains the features, installation, startup and maintenance of the INV2000 Standalone Inverter.

NOTE: *Images contained in this document are for illustrative purposes only and may not exactly match your installation.*

1.2 Product Overview

To expand the quality power range and fulfilling the desperate demand of the total power solution for the telecom power applications, the INVERTER 2000 provides reliable 2000W capacity in compact 1RU height, 19" width rack design metal housing.

The higher efficiency, better over load performance, compact appearance makes INVERTER 2000 an outstanding and perfect reliable power solutions for all types of telecom applications.

Furthermore, The INVERTER 2000 with built-in ATS function can largely increase the reliability by automatic switch between the inverter output and other alternative AC sources which provide extra safety for uninterruptible power. INVERTER 2000 is the indispensable power equipment for your reliable telecom system.

Features:

- Designed for telecom system application
- High quality pure sine wave output
- Extraordinary overload capability: 120% overload continuously, 200% overload for up to 5 seconds
- Remarkable efficiency: up to 91%
- Unity output power factor
- DSP chip design for reliable performance
- Optional built-in auto transfer switch for increasing alternative reliability
- LCD display for real time status monitoring and setting
- USB interface for communication and connecting to PC
- RoHS compliance
- Low audible noise <55dBa
- Wide operation temperature range, -20~60°C



Figure 1—INV2000 Standalone Inverter

2 Inspection

2.1 Packing Materials

All Argus products are shipped in rugged, double walled boxes and suspended via solid inserts to minimize shock that may occur during transportation. Packaging assemblies and methods are tested to International Safe Transit Association standards.

2.1.1 Returns for Service

Save the original shipping container. If the product needs to be returned for service, it should be packaged in its original shipping container. If the original container is unavailable, make sure the product is packed with at least three inches of shock-absorbing material to prevent shipping damage.

NOTE: *Argus Technologies is not responsible for damage caused by the improper packaging of returned products.*

2.2 Check for Damage

Prior to unpacking the equipment, perform a visual inspection and note any damage. Unpack the equipment and inspect the exterior for damage. If any damage is observed contact the carrier immediately.

In addition to the inverter module (Figure 1), the mounting kit provided consists of:

4 x M4 screws to connect the brackets to the cabinet:



23" mounting brackets:



Parallel signal port cover:



Continue the inspection for any internal damage. In the unlikely event of internal damage, please inform the carrier and contact Argus Technologies for advice on the consequence of any damage.



Verify that you have all the necessary parts per your order for proper assembly.



Call Argus Technologies if you have any questions before you proceed: 1 (888) 462-7487
Customers outside Canada and the USA, call +1-604-436-5547 for technical support.

3 Installation and Wiring

3.1 Where to Install

The power inverter should be installed in a location that meets the following requirements:

- **Dry:** Do not allow water to drip or splash on the inverter.
- **Cool:** Ambient air temperature should be between -20°C and 60°C.
- **Safe:** Do not install in a battery compartment or other areas where flammable fumes may exist, such as fuel storage areas or engine compartments.
- **Ventilated:** Allow at least three inches of clearance around the inverter for airflow, ensuring that the ventilation openings on the front, rear and top of the unit are not obstructed.
- **Dust Free:** Do not install the inverter in a dusty environment where dust, wood particles or other filings/shavings are present that may be pulled into the unit when the cooling fan is operating.
- **Close to Batteries:** Avoid excessive cable lengths but do not install the inverter in the same compartment as batteries. Use the recommended wire lengths and sizes (see section 3.5).

Avoid mounting the inverter where it may be exposed to the gases produced by the battery. Prolonged exposure to these corrosive gases will damage the inverter.

3.2 Unit Installation

The unit is pre-installed with 19-inch rack brackets. Put the unit to the rack horizontally, and align holes of mounting brackets and rack. Secure the unit in position with four cross-pan type nickel screws.

3.3 Unit Removal

The unit can be removed from the equipment rack by screwing off the retaining screws.

3.4 AC Safety Grounding

During the AC wiring installation, AC input and output ground wires are connected to the inverter. The AC input ground wire must connect to the incoming ground from your AC utility source.

The AC output ground wire should go to the grounding point for your loads.



WARNING

Do not operate the unit without connecting it to ground. Electrical shock hazard may result.

3.5 DC Wiring Connections

Connect the cables to the power input terminals on the rear panel of the unit.

[+] is positive, and **[-]** is negative. Insert the cables into the terminals and tighten the nut to securely clamp the wires.

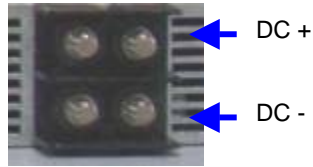

Figure 2–DC input terminals



WARNING

Before proceeding, confirm that DC input cable connect correctly.

Make sure that all DC connections are tight (torque to 9-10 foot pounds). Loose connections will overheat and could result in a potential hazard.

Follow this procedure to connect the battery cables to the DC input terminals on the unit.

The cables should be as short as possible (ideally, less than 10 feet / 3 meters) and large enough to handle the required current in accordance with the electrical codes or regulations applicable to your installation. Cables that are not an adequate gauge (too narrow) or are too long will cause decreased inverter performance such as poor surge capability and frequent low input voltage warnings and shutdowns. These low input voltage warnings are due to DC voltage drip across the cables from the inverter to the batteries. The longer and narrower these cables, the greater the voltage drop.

CAUTION – Increasing your DC cable size will help improve the situation.

NOTE: *We recommend #6 AWG 40A cables (48Vdc input) for optimum inverter performance (applies to both 110V and 220V series). Use only high quality copper wiring and keep cable length short (from 3-6 feet).*

4 Operation

4.1 Front Panel

Located on the front panel is the interface for signals and controls:

- **Control:** Keypad to set major parameters
- **Remote Control/Monitoring:** USB
- **Display:** LCD and 3-LEDs to display major parameters, status and alarms



Figure 3–Front panel

4.1.1 ON/OFF Switch

The POWER ON/OFF switch is a lock switch that turns the unit on or off by pressing it once.

4.1.1.1 Switch on:

When the unit is connected to the DC, LCD will show content, press ON/OFF switch, unit will provide power to load in 20s.

When the unit is only connected to the AC, LCD will show content, press ON/OFF switch, unit will provide power to load in 5s.

4.1.1.2 Switch off:

When unit is working, press ON/OFF switch will turn unit off, if DC or AC power exists, LCD will show content continually.

Unit shuts off when input power out of range, and it can auto restart if on/off switch is at on position and input DC or AC power recover.

4.1.2 USB Port

User can operate Hyper terminal by connect the USB Cable to the USB interface on the front panel. The USB is 1.1.

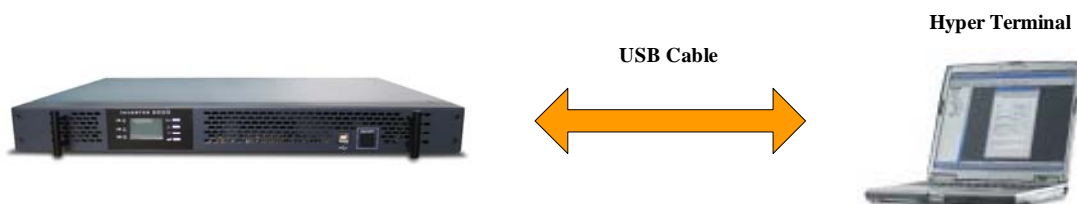

Figure 4–USB connectivity

4.1.3 LED Indicators









Inverter Module LED Display Status			
Priority	Green LED	LED Signal	Status
Low ↓ High	Solid		Inverter work normally
	Blink (intermittent (slow))		One of the status as follows: 1) Power On. Details refer to note. 2) Shut down remotely.
Priority	Yellow LED	LED Signal	Status
Low ↓ High	Blink (intermittent (slow))		Power On Details refer to note.
	Solid		One of the alarms as follows: 1) Over Load (Load > 105%); 2) DC input abnormal. (Vin<=45V or Vin>=58V)
	Blink (intermittent (fast))		Inverter shut down due to DC super low/super high input. (Vin<=VLVSD or Vin>=VHVSD)
Priority	Red LED	LED Signal	Status
Low ↓ High	Blink (slow)		One of the alarms as follows: 1) EEPROM Fault; 2) Inverter Fan Fault.
	Blink (fast)		One of the alarms as follows: 1) Internal fault; 2) Temperature High.
	Solid		One of the alarms as follows: 1) Input reverse polarity; 2) Inverter output Short circuit; 3) Abnormal output voltage; 4) Negative Power Protection; 5) Overload fault.

Table A–Inverter LED indicator display

4.1.3.1 Power On:

When the inverter is in “Power On” mode, the green LED and the yellow LED are flickering synchronously without any alarm.

4.1.3.2 Overload and Overload Fault:

When overload fault alarm occurs, the yellow LED and red LED turn on at the same time, while overload alarm occurs, only the yellow LED turns on.

4.1.3.3 Priority:

If more than one warning exists at the same time, then the LED will display the highest priority.

4.1.4 LCD Menu Structure

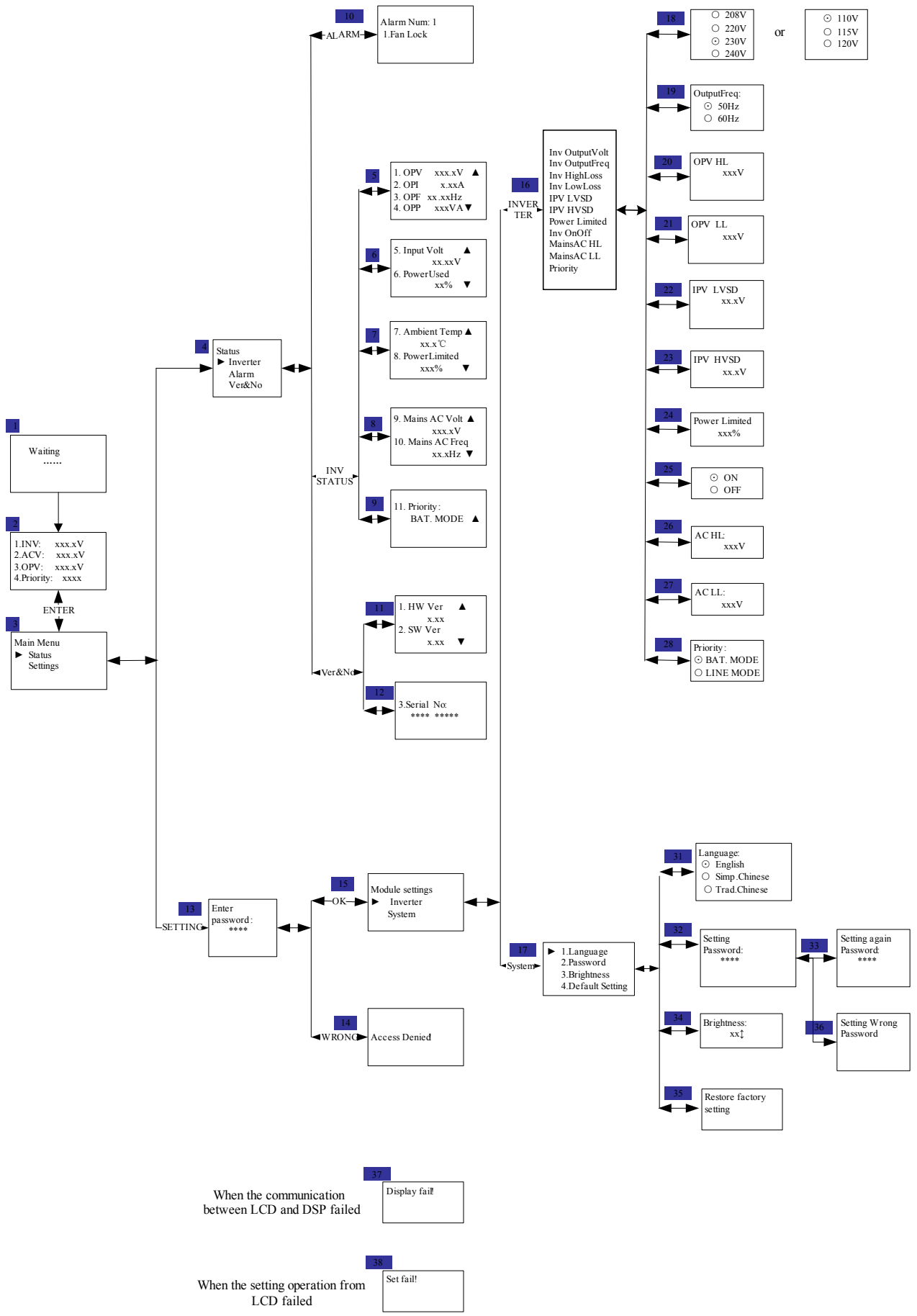

4.2 Rear Panel

Located on the rear panel are the terminations for wiring:

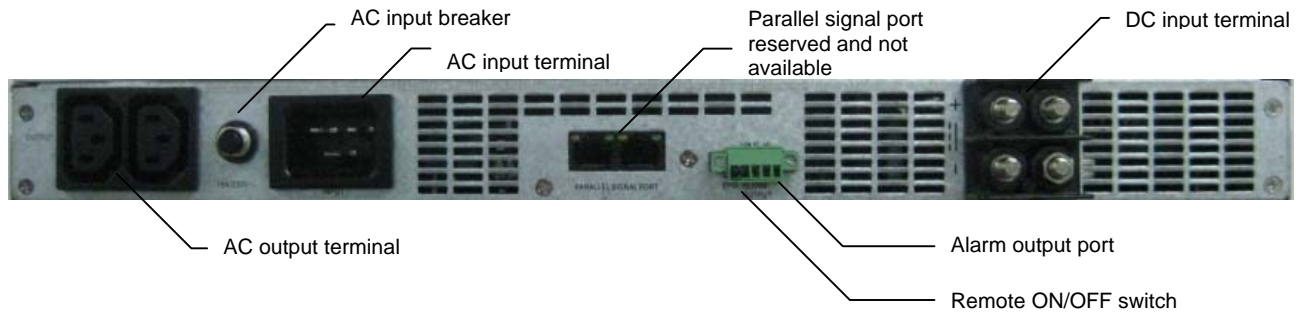

Figure 5–Rear panel

4.2.1 DC Input

ST722B2502 (300 Volts (UL 1059 Class B and C) / 175 Amps)

Wire Range #2 - #8

(Accommodates two-hole compression lugs on 0.625" centers – wires #2 and larger may require narrow lugs)

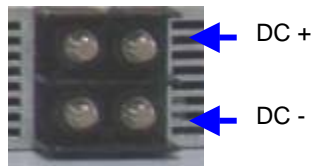

Figure 6–DC input terminals

Connect to a 48Vdc battery or DC power source.

Upper terminal **[+]** is positive, and **[-]** is negative. Reverse polarity connection will cause red alarm LED to illuminate (indicator solid), but inverter will not be damaged.

4.2.2 AC Input

230Vac model: RECEPTACLE /WS-044-7 16A 250V INLET GAP1.5

120Vac model: cable P.C.#12*3C 20A 125Vac 5-20P UL 2200

4.2.3 AC Input Breaker

230Vac model: N.F.B1P15A 250Vac JOEMEX/PE747415-214D-051

120Vac model: NFB 1P20A/120Vac (CIRCUIT PROTECTOR) UL489

4.2.4 AC Output

230Vac model: AC output outlet IEC320-C13 10A 250Vac

120Vac model: REC. RON/RF-6005-A 5-20R 20A 125V 3P

4.2.5 Alarm Relay

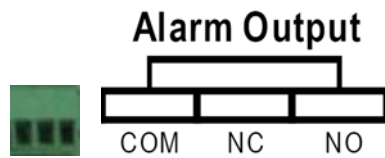
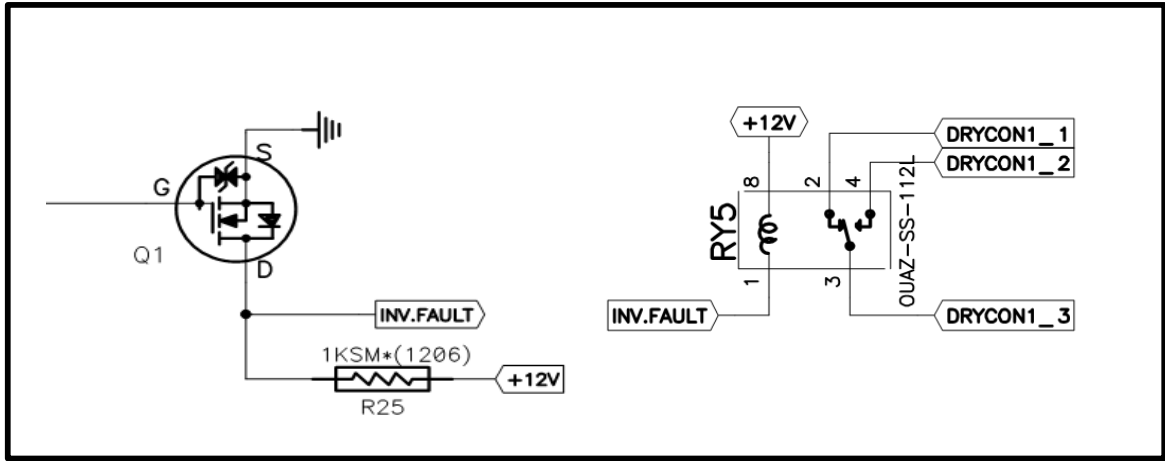
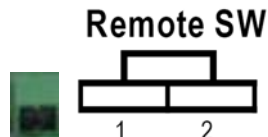
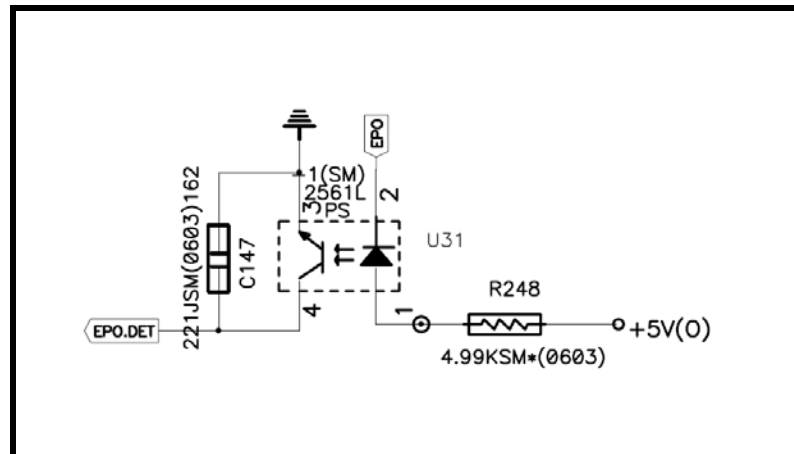

Figure 7–Rear panel alarm output port

4.2.6 Remote ON/OFF Switch

Inverter will be turned on/ off after remote Switch 0.5s.

PIN1, PIN2 open, unit will be remote off; closed, unit will work.



Remote SW	Output Status
Open	Off
Close	On

Figure 8–Rear panel remote ON/OFF switch

Once the module is ON use this switch to stop unit remotely.

Restart method: close the remote switch - unit will auto restart.

Remote switch is available when power ON/OFF switch is at “ON” position.

4.3 Pre-Operation Check

Inverter Operation Check

- Check if the DC input polarity is connected correspondingly.
- Ensure the input voltage is in the standard range.
- Check corrected connecting wiring size based on the wiring table.
- Check if the ground wiring is connected on rear cover for safety, avoiding electrical shock.
- The breakers are at ON position.
- To operate the Auto Transfer Switch it is necessary to make sure that the nominal voltage and frequency of the grid match the corresponding settings of the unit.

Verify that the nominal frequency and voltage values are equal to those of the grid.

4.4 Status Monitoring

When the inverter is properly installed with power on, the LCD screen would light by displaying “Waiting” for self-diagnosis. Few seconds after, general status is shown as follows.



Figure 9–Power start page

Press “Enter” key, “Main Menu” will be shown as follow, “STATUS” and “SETTINGS” menu can be selected via pressing “PgDn” or “PgUp” and “Enter” key.



Figure 10–Main menu

Heading	Value
Address	Inverter module location
OPV	Output voltage of the inverter module in Volts (V)
OPI	Output current of the inverter module in Amperes (A)
OPF	Output frequency of the inverter module in Hertz (Hz)
OPP	Power capacity of the inverter module in Volt-Amperes (VA)
Input Volt	DC input voltage of the inverter in Volts (V)
Power Used	Load level in percentage (%)
Ambient Temp.	Inverter ambient temperature (°C)
Power Limited	Power limited in percentage (%)
Mains AC Volt	Voltage of Mains AC
Mains AC Freq	Frequency of Mains AC
Priority	On-line/Off-line

Table B–LCD display of inverter status

Item	Specification	Remark
Inverter	Alarm name	For example: <div style="border: 1px solid black; padding: 5px; width: fit-content; margin: 10px auto;"> Alarm Num: 1 1. Fan Lock </div>

Table C–LCD display of alarm log

Heading	Value
HW Ver	Hardware version of the inverter module
SW Ver	Software version of the inverter module
Serial No.	The serial number of the inverter

Table D–LCD display of version and SN

4.5 Parameter Settings

Inverter allows some parameters reset through the key function and LCD. Use PgDn▽ key and Enter ← key to select SETTINGS. 4-digit numeric password is requested. Use PgUp△ key to increase number, and PgDn▽ key to decrease number. For instance, press PgUp△ key once for 1, twice for 2, three times for 3, and so on. Press Enter ← to validate each digit of password once the desired number is selected. The default password is 0000. No setting modification can be executed if a wrong password is entered.



Figure 11–Password input

Password Setting

1. A new password can be set in **SYSTEM** option under **SETTINGS**. Press Enter ← key to enter **SETTING PASSWORD** menu for resetting password.
2. Use PgUp△ key and PgDn▽ key to key in new password. Press Enter ← to validate each digit of password once the desired number is selected.
3. After 4-digit new password is input, the inverter would ask to re-key in the new password as confirmation. Repeat Step 2 to key in the new password again. Once the password is successfully changed, **DONE** will appear on the screen.

SETTINGS section is divided into two categories: **SYSTEM** and **INVERTER**.

4.5.1 System Parameter Settings

Parameter	Specification
Language	English
Password	Setting password
Brightness: LCD Brightness	From 00~63 for adjusting LCD display contrast
Restore Factory Setting	Reset default value

Table E–System parameter settings

4.5.2 Inverter Parameter Settings

Parameter	Setting Option
Output volt: Inverter output voltage	For 230Vac output, selectable at: 1) 208Vac 2) 220Vac 3) 230Vac 4) 240Vac For 110Vac output, selectable at: 1) 110Vac 2) 115Vac 3) 120Vac
Output Freq: Inverter output frequency	Selectable at 1) 50Hz and 2) 60Hz
OPV HL: High loss of inverter output voltage	For Output volt = 208V, adjustable between 220V and 240V For Output volt = 220V, adjustable between 233V and 252V For Output volt = 230V, adjustable between 244V and 264V For Output volt = 240V, adjustable between 254V and 276V For Output volt = 110V, adjustable between 117V and 127V For Output volt = 115V, adjustable between 122V and 132V For Output volt = 120V, adjustable between 127V and 138V
OPV LL: Low loss of inverter output voltage	For Output volt = 208V, adjustable between 176V and 198V For Output volt = 220V, adjustable between 176V and 209V For Output volt = 230V, adjustable between 185V and 218V For Output volt = 240V, adjustable between 193V and 228V For Output volt = 110V, adjustable between 89V and 105V For Output volt = 115V, adjustable between 93V and 110V For Output volt = 120V, adjustable between 100V and 114V
IPV LVSD: The maximal input voltage for inverter normal operation	Adjustable between 39V and 44V
IPV HVSD: The minimal input voltage for inverter normal operation	Adjustable between 59V and 61V
Power Limited: Inverter output power capacity	Adjustable between 50% and 100%
Inverter On/off: Setting inverter turn on or off	<input type="radio"/> ON <input type="radio"/> OFF
AC HL: High loss of alternative AC input	xxxV
AC LL: Low loss of alternative AC input	xxxV
Priority	Bat. Mode / Line Mode

Table F–Inverter parameter settings

4.6 Alarm Settings

Use #30~16 AWG to connect dry contact:

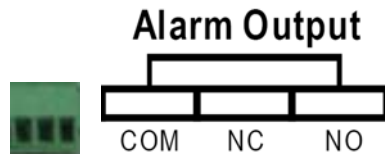

Figure 12–Rear panel alarm output port

4.7 Remote ON/OFF Switch

Use #30~16 AWG to connect remote ON/OFF switch:



Remote SW	Output Status
Open	Off
Close	On

Figure 13–Rear panel remote ON/OFF switch

4.8 Turning On The Load

Check that the rated input power of the load is less or equal to the rated output power of the inverter.

Connect the load to the inverter as described previously.

Press the ON/OFF key to turn the unit ON.

5 Maintenance and Troubleshooting

5.1 Preventative Maintenance

The following preventive maintenance routines should be considered as a minimum requirement. Your installation may require additional preventive maintenance to assure optimal performance from your installed inverter and associated equipment. These routines should be performed twice a year (more often if required). We strongly recommend a contract with Customer Support Services for preventive and remedial maintenance. The technician or electrician performing preventive maintenance on the equipment must read and understand thoroughly this manual and be familiar with the indicators, controls, and operation of the equipment.

5.2 Troubleshooting Guide

If the inverter fails to operate properly after having the installation and setup of the inverter thoroughly re-examined, use the troubleshooting table to determine the probable cause(s) and solution(s) to resolve error conditions. For unlisted error conditions, please contact your local dealer for technical assistance.

Error Condition	Possible Cause	Recommendation
No AC output and all LEDs off.	Lack of input power.	Ensure input cables are all firmly connected to power source. Check if power source is not yet switched on, or is low in power.
No AC output. Both green and yellow LEDs flicker.	Inverter self-diagnosis.	Inverter self-diagnosis takes a few seconds. LED turns to a solid green light after the completion of self-diagnosis.
No AC output. Both yellow and red LEDs are on.	Load exceeds 125%.	Ensure the load is no higher than 105% of the total power rating. Reduce as required.
No AC output. Red LED is on.	1. Input wiring is connected in reverse (i.e. reverse polarity).	Ensure input cables are connected to correct polarity (positive to positive, negative to negative).
	2. Internal fault.	Restart the unit. If it fails to work, return it to factory for repair.
	3. Inverter output is shorted.	Turn off the input power source to remove all short circuits.
	4. Negative Power Protection.	When transfer between Mains and inverter, mains backfeed to inverter.
Red LED blinks fast.	1. Inverter fails to soft start.	Reboot the inverter system by switching off and on the input power source.
	2. Inverter temperature rises beyond the temperature limit.	Leave inverter idle to cool down for few minutes.
AC output exists with yellow LED flickering.	Input voltage is out of operating range.	Ensure input voltage is between 45 to 58Vdc.
AC output exists and yellow LED is on.	Load is over 100% but below 125%.	Ensure the load is no higher than 105% of the total power rating. Reduce as required.
Inverter continuously delivers power, but with red LED flickering slowly.	Failure of EEPROM.	Reboot the inverter system by switching off and on the input power source.
	Fans failure.	Check if the fans are locked or fail to work. If fan is locked, remove the obstruction; if fan fails to work, replace the fan.

Table G–Troubleshooting for inverter module

6 Default Values

Alarm Name	Level	Remark	Output Status
Inverter fault	Critical	Inverter fault	Off
Over load	Observe	Inverter over-loading	On
Over load fail	Critical	Over load shut down	Off
Inv fan fault	Major	Inverter fan fault	On
Power limit	Observe	Inverter power limited	On
DC abnormal	Observe	Inverter input out of range	On
DC low Inv off	Observe	Inverter shut down due to low input voltage	Off
Inv Bus High	Critical	Inverter Bus voltage over the maximum level	Off
Inv Bus Low	Critical	Inverter Bus voltage under the minimum level	Off
BusSoft fail	Critical	Inverter Bus soft start fail	Off
Output short	Critical	Inverter output short circuit	Off
Inv OPV Low	Critical	Inverter output voltage low	Off
Inv OPV High	Critical	Inverter output voltage high	Off
Inv Temp High	Critical	Inverter temperature high	Off
NegPow Protect	Critical	Inverter negative power protection	Off
SoftStart fail	Critical	Inverter soft start fail	Off
Mains abnormal	Observe	Mains unavailable	On
Eeprom fail	Major	Inverter EEPROM fault	On

Table H–Alarm default levels

NOTE: *Critical level fault needs manual restart.*

Setting	Default Value
ATS priority	On-line
230Vac Unit	
Mains high loss volt	276V
Mains low loss volt	176V
Inverter output high loss volt	264V
Inverter output low loss volt	192V
Inverter shutdown due to low input volt	40V
Inverter shutdown due to high input volt	60V
Inverter output volt	230V
Inverter output volt frequency	50Hz
Inverter output power limit	100%
120Vac Unit	
Mains high loss volt	138V
Mains low loss volt	89V
Inverter output high loss volt	140V
Inverter output low loss volt	90V
Inverter shutdown due to low input volt	40V
Inverter shutdown due to high input volt	60V
Inverter output volt	120V
Inverter output volt frequency	60Hz
Inverter output power limit	100%
System Parameter	
LCD brightness value	45
Language	English
Password	0000

Table I–Inverter/System factory defaults

7 Argus Conventions

7.1 Numbering System

Argus Technologies uses an eight-digit drawing number system, which is broken into three blocks. The first three digits describe the category of the product; e.g., rectifier or fuse panel. The next three digits indicate the sequence in which the product number was allocated in a particular category. The last two digits indicate the type of drawing, for example:

"-06"	Outline Drawing
"-08"	Customer Connections
"-20"	Main Assembly

Argus uses an eight-digit part numbering system for all components and sub assemblies. Each part is covered by its own unique number. Due to the quantity, categories will not be listed within this manual.

7.2 Acronyms and Definitions

AC	Alternating current
ANSI	American National Standards Institute
ATS	Automatic Transfer Switch
AWG	American Wire Gauge
COM	Common
CSA	Canadian Standards Association
DC	Direct current
DSP	Digital signal processor
EMC	Electromagnetic compatibility
HVSD	<u>H</u> igh <u>v</u> oltage <u>s</u> hutdown
IEC	International Electrotechnical Commission
LCD	Liquid crystal display
LED	Light emitting diode
LVSD	<u>L</u> ow <u>v</u> oltage <u>s</u> hutdown
MTBF	Mean time between failures
NC	Normally closed
NO	Normally open
OSHA	Occupational Safety & Health Administration
PC	Personal computer
RoHS	Restriction of hazardous substances
RU	Rack unit (1.75")
THD	Total harmonic distortion
UL	Underwriters Laboratories
USB	Universal serial bus

8 Outline Drawings

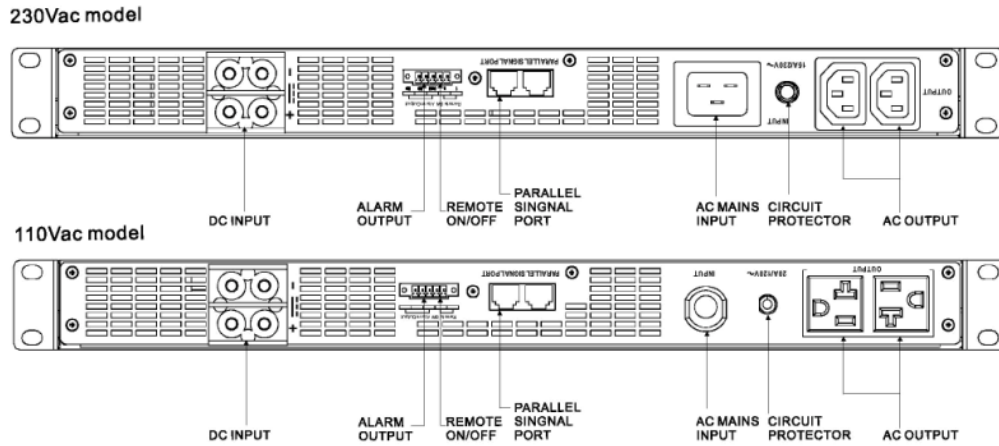

Figure 14–Rear panel views

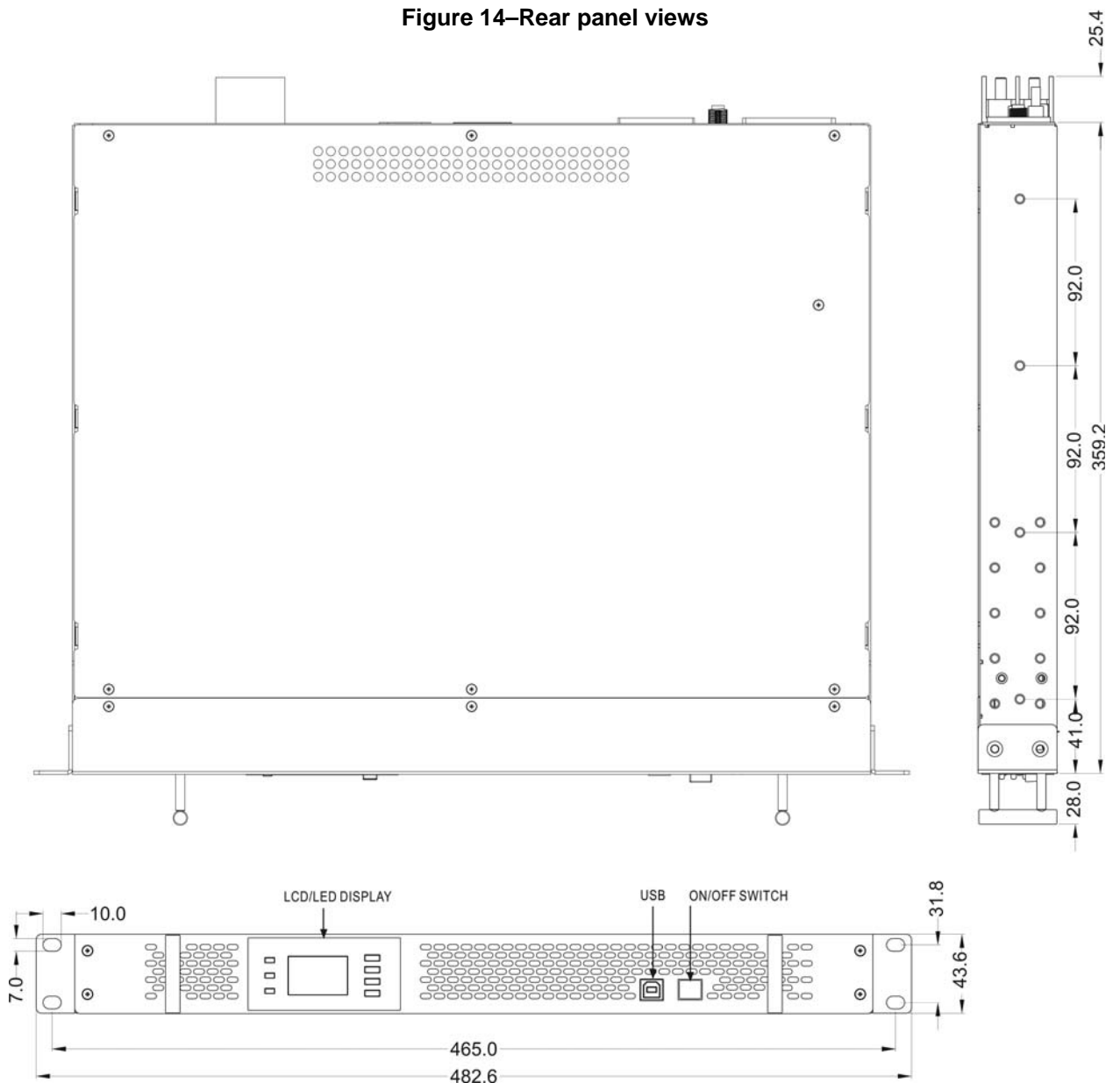

Figure 15–Dimensional views

Service Centers

Factory Service Centers

Canada and International

Argus Technologies Ltd.
ATTN: RMA Returns
7033 Antrim Avenue
Burnaby, BC, V5J 4M5 Canada
Tel: +1 604 436 5900
Fax: +1 604 436 1233
Email: returns@argusdcpower.com

USA

Argus Technologies Inc.
ATTN: RMA Returns
3116 Mercer Avenue
Bellingham, WA, 98225 USA
Tel: +1-360 756 4904
Fax: +1-360 647 0498
Email: returns-usa@argusdcpower.com

Asia-Pacific

PCM Electronics (Dong Guan) Co., Ltd.
Hongli Industrial Area, Miaobian,
Liaobu Town, Dongguan City,
Guangdong Province, 523400 China
Tel: +86 755 8895 3310
Fax: +86 755 8895 3307

Authorized Service Center

Argentina

Argus Technologies de Argentina
Belen 315, Capital Federal, Buenos
Aires,
14071 Argentina
Tel: +54 (11) 4672 4821
Fax: +54 (11) 4504 4698
Cell: +54 9 (11) 4993 9996
Email: lkleiman@argus.ca

Asia

Argus Technologies Asia Pte Ltd
Blk 6 Tagore Lane #160
Singapore 787570
Tel: +65 6458 8900
Fax: +65 6458 2122

Australia

CPS National
8/376 Newbridge Rd
Moorebank, NSW, 2170 Australia
Tel: +61 02 9822 8977
Fax: +61 02 9822 8077

Australia/New Zealand

Alpha Power Systems Pty Ltd.
Unit 3, 30 Heathcote Road
Moorebank, NSW, 2170 Australia
Tel: +61 02 9602 8331
Fax: +61 02 9602 9180

Century Yuasa

37 - 65 Colbalt Street
Carole Park QLD 4300
Australian Sales & Service
Tel: +61 07 3361 6587
Fax: +61 07 3361 6705
New Zealand Sales & Service
Tel: +64 9 978 6689
Fax: +64 9 978 6677

Brazil

Argus Brasil Serviços e Comércio Ltda
Rua: Constituição, 145/147 - Santos
São Paulo - Brasil 11015-471
Tel: +55 (13) 3234 2469
Fax: +55 (13) 3234 2469
Cell: +55 (13) 7806 1438
Email: argusbrasil@bignet.com.br

Canada

Compower Systems Inc.
118 Tiffield Road
Toronto, ON, M1V 5N2 Canada
Tel: +1 416 293 3088
Fax: +1 416 293 0671

Europe

Alpha Technologies Europe Ltd.
Cartel Business Estate
Edinburgh Way
Harlow, Essex, CM20 2DU UK
Tel: +44 1279 422110
Fax: +44 1279 423355

Mexico & Central America

Technologies Argus First De Mexico
SA de CV
Anatole France No. 17
Col. Polanco
Mexico City, 11560 Mexico
Tel: +52 55 5280 6990
Fax: +52 55 5280 6585

Romania

Alphapower SRL
Str. Paul Constantinescu nr.5
Timisoara, Romania
Tel: +40 21 569 1214
Cell: +40 31 816 1491

South America

Argus Technologies Argentina
Santo Tome 2573, Capital Federal
Buenos Aires, 1416 Argentina
Tel: +54 11 4504 4698
Cell: +54 9 11 4993 9996
E-pager: 541149939996@nextel.net.ar

Turkey

IPC Enerji Elk San ve TIC AS
Inonu cad. Kanarya sok. No:20
Yenisahra - Kadikoy
Istanbul, Turkey
Tel: +90 216 317 41 42
Fax: +90 216 472 90 66